

cinelli

2024 line



2024 bicycles and frames line

PLEASE NOTE SPECS MAY VARY.

index

04 - 2024 year product overview

06 - road

42 - gravel

62 - adventure

76 - urban



2024 year



product overview

ROAD



pressure p. 06
Aero road racer, crits & grand tours



nemo tig road p. 26
Handmade in Italy, endurance racing & epic rides



pressure adr p. 10
Long distance racer, grand tours & epic rides



nemo tig road rim p. 30
Handmade in Italy, endurance racing & epic rides



superstar p. 14
The ultimate all-rounder: gran fondos, climbing, descending & sprinting



nemo tig allroad p. 34
Handmade in Italy go-anywhere: road, gravel, winter-training & adventures



xcr p. 18
Ultralight steel masterpiece, endurance racing & epic rides



supercorsa p. 38
The Original lugged Italian road bike, Eroica-approved



xcr rim p. 22
Ultralight steel masterpiece, endurance racing & epic rides

GRAVEL



king zydeco p. 42
Fast gravel and epic racing



zydeco p. 46
Go anywhere: gravel, road, light bikepacking & fast commuting



zydeco lala p. 50
Go anywhere: gravel, road, light bikepacking & fast commuting



zydeco electric mud p. 54
Fast, ultralight, electric gravel riding



nemo tig gravel p. 58
handmade in Italy, extreme gravel riding and ultra racing

ADVENTURE



hobootleg p. 62
Unsupported long-distance adventure riding



hobootleg geo p. 66
Unsupported off-road long distance adventure riding



hobootleg easy travel p. 70
Fast commuting, weekend adventures



hobootleg interrail p. 74
Flat bar fast adventure riding, year-round commuting

URBAN



tutto mini silver bootleg p. 78
Bmx meets fixed meets gravel, fast & fun city (and beyond) riding



zydeco silver bootleg p. 82
Fast, all conditions, commuting and gravel riding



tutto plus silver bootleg p. 86
Multi-purpose singlespeed, fast urban and light gravel



vigorelli p. 90
Fixed gear icon, velodrome-tuned



gazzetta della strada p. 94
Stylish, practical, city riding and weekend adventures



pressure

Born to race, Pressure synthesizes the needs of performance cycling into the language of contemporary Milanese design.





pressure

frame-kit - complete bike

- Pinnacle of Cinelli's road bike design language
- Aerodynamic tube profile
- Integrated wiring aero cockpit
- Integrated seatpost
- T800 High modulus carbon fiber
- Max tyre clearance 700x30c

Born to race, Pressure is the pinnacle of Cinelli's road bike design language. Made from a high modulus T800 carbon fiber with proprietary lay-up tested and developed in conjunction with Italy's premier development team, Colpack Ballan CSB over a period of two years, the Pressure synthesizes into a contemporary Milanese design language the performance cyclist's need for aerodynamic tube profiles, integrated wiring and an aggressive road feel that pays homage to our historical Italian racing DNA... Various prestigious professional victories include the 2021 UCI U23 Mens World Championships with Filippo Baroncini.



specs

FRAME WEIGHT (M)	FORK WEIGHT (M)	PRESS FIT	MAX TYRE
990 g	390 g	BB 86,5	30 mm

Triple White



Triple Grey



Triple Black



Team Limited

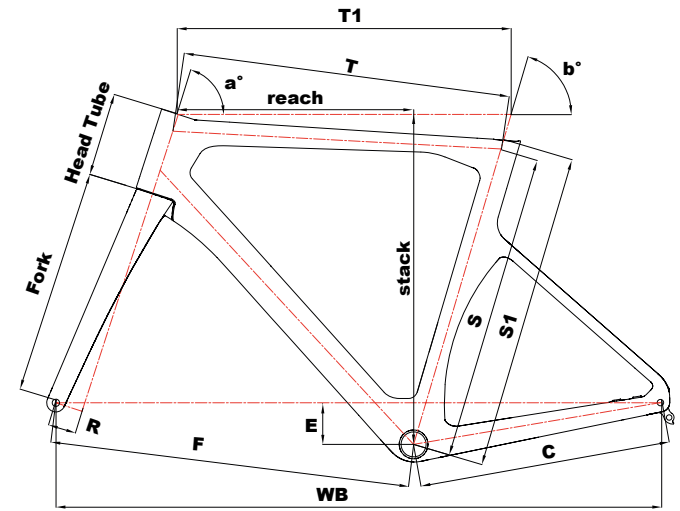

geometry

	S1	S	T1	T	H/T	A	B	R	C	F	WB	E	FORK STACK	REACH	
XS	460	444	518	504	110	71	73,5	45	410	571	971	68	374	512	366
S	490	472	530	518	125	71,5	73,5	45	410	579	979	68	374	528	374
M	520	503	545	538	135	72	73,5	45	410	590	990	68	374	539	385
L	550	535	560	556	155	72,5	73,5	45	410	600	1001	68	374	560	394
XL	580	567	575	573	175	73	73,5	45	410	611	1011	68	374	581	403

assembly

	RED ETAP axs	DURA-ACE DISC DI2	ULTEGRA DISC DI2	ULTEGRA DISC 11v	105 DISC DI2
Drivetrain	Sram Red Etap AXS	Shimano Dura-Ace 9270	Shimano Ultegra 8170	Shimano Ultegra 8020	Shimano 105 7100
Handlebar	FSA Metron 5D ACR	FSA Metron 5D ACR	FSA Metron 5D ACR	FSA Metron 5D ACR	FSA Metron 5D ACR
Stem	/	/	/	/	/
Seatpost	Integrated	Integrated	Integrated	Integrated	Integrated
Shifters	Sram Red Etap AXS	Shimano Dura-Ace R9270	Shimano Ultegra R8170	Shimano Ultegra R8020	Shimano 105 R7170
Brakes	Sram Red	Shimano Dura-Ace R9270	Shimano Ultegra R8170	Shimano Ultegra R8070	Shimano 105 R7170
Rotors	Sram Centerline XR 160 - 140 mm	Shimano 160 - 140 mm	Shimano 160 - 140 mm	Shimano 160 - 140 mm	Shimano 160 - 140 mm
Ft. derailleur	Sram Red Etap AXS	Shimano Dura-Ace R9250	Shimano Ultegra R8150	Shimano Ultegra R8000	Shimano 105 R7150
R. derailleur	Sram Red Etap AXS	Shimano Dura-Ace R9250	Shimano Ultegra R8150	Shimano Ultegra R8000	Shimano 105 R7150
Crankset	Sram Red Etap AXS 48/35t	Shimano Dura-Ace R9200 52/36t	Shimano Ultegra R8100 52/36t	Shimano Ultegra R8000 52/36t	Shimano 105 R7100 52/36T
Cassette	Sram Red Etap AXS 10/28t	Shimano Dura-Ace R9200 11/30t	Shimano Ultegra R8100 11/30t	Shimano Ultegra R8000 11/30t	Shimano 105 R7100 11/34T
Chain	Sram Red Flathead	Shimano M9100	Shimano M8100	Shimano Ultegra R8000	Shimano M7100
Wheelset	Fulcrum Wind DB	Fulcrum Wind DB	Fulcrum 600 DB	Fulcrum 600 DB	Fulcrum 600 DB
Tyres	Pirelli PZero Race 700x28	Pirelli PZero Race 700x28	Vittoria Zaffiro pro 700x28	Vittoria Zaffiro pro 700x28	Vittoria Zaffiro pro 700x28
Saddle	Selle Italia Novus Boost	Selle Italia Novus Boost	Selle Italia Model X	Selle Italia Model X	Selle Italia Model X

frame specs

Sizes	XS (46) - S (49) - M (52) - L (55) - XL (58)
Cockpit	XS 100x40 - S 100x40 - M 110x42 - L 110x42 - XL 120x42 Included
Material	Columbus Carbon Monocoque T800
Headset	IS 52/28,6 IS 52/40 FSA ACR 1-1/2" (included)
Seatpost	Aero (included) / Carbon Rail Comp. / L 300 (XS) - L 350 (S-M-L-XL)
Seat Clamp	Hidden (included)
BB Shell	Press Fit 86,5 x 41 mm
Ft. derailleur	Braze-On
Routing	Full Internal - Di2/EPS Compatible
Color	Triple White / Triple Grey / Triple Black / Team Limited
Tyre Clear.	up to 700x30 mm
Fork	Columbus Disc 1-1/2" Carbon Monocoque Internal Cable Routing
Weight	Frame 990g (size M) - Fork 390g (uncut)
Brake	Flat Mount Disc Brake, Rotor Size Up To 160 mm
Dropouts ST	Rear TA Ø 12x142mm - M12x165 / Front TA Ø 12x100mm - M12x120
Highlights	Extra hanger / Di2 / EPS Cable Inserts / F-R Skewers

pressure adr

The Pressure ADR maintains our Pressure's pure competition handling and feel, augmented with all-day-race comfort for epic racing.





PRESSURE ADR

cinelli

cinelli

SE
CIA

SE
CIA

TTT

pressure adr

frame-kit - complete bike

- The same racing feel and handling as our top-of-the-range Pressure
- Fine-tuned tubing sections and carbon fiber layup for improved comfort
- Integrated cable routing
- 27,2mm seatpost for greater comfort
- Standard seatpost and fork steerer diameters allow the user to progressively upgrade with world leading after-market component solutions



The Pressure ADR continues to refine the design and performance developments of our aero-racer, the Pressure fine tuning it for epic, long-distance racing. The ADR in fact maintains the signature pure competition handling and feek of the Pressure, fine-tuning tube sections and carbon fiber lay-up to make it more suitable for long hours in the saddle. These engineering considerations are complemented by fully-integrated cable routing and the use of standard seatpost and fork steerer diameters, allowing the owner to easily install world-leading after market component solutions.

specs

FRAME WEIGHT (M)	FORK WEIGHT (M)	PRESS FIT	MAX TYRE
990 g	420 g	BB 86,5	30 mm

Triple White Slow Fade



Triple Grey Slow Fade



Midnight Scream



assembly semi-hidden cable routing

	DURA-ACE DISC D12	ULTEGRA DISC D12	105 DISC D12	ULTEGRA DISC 11v
Colour	All Colours	All Colours	All Colours	All Colours
Drivetrain	Shimano Dura-Ace R9270	Ultegra Di2 12v	105 Di2	Ultegra Disc 11v
Handlebar	Cinelli Boss	Cinelli Boss	Cinelli Boss	Cinelli Boss
Stem	Alu 6061	Alu 6061	Alu 6061	Alu 6061
Seatpost	Cinelli 6061 ø 27,2	Cinelli 6061 ø 27,2	Cinelli 6061 ø 27,2	Cinelli 6061 ø 27,2
Shifters	Shimano Dura-Ace R9270	Shimano Ultegra R8170	Shimano 105 R7170	Shimano Ultegra R8070
Brakes	Shimano Dura-Ace R9270	Shimano Ultegra R8170	Shimano 105 R7170	Shimano Ultegra R8070
Rotors	Shimano 160 - 140 mm	Shimano 160 - 140 mm	Shimano 160 - 140 mm	Shimano 160 - 140 mm
Ft. derailleur	Shimano Dura-Ace R9250	Shimano Ultegra R8150	Shimano 105 R7150	Shimano Ultegra R8000
R. derailleur	Shimano Dura-Ace R9250	Shimano Ultegra R8150	Shimano 105 R7150	Shimano Ultegra R8000
Crankset	Shimano Dura-Ace R9200 52/36t	Shimano Ultegra R8100 52/36t	Shimano 105 R7100 50/34T	Shimano Ultegra R8000 52/36t
Cassette	Shimano Dura-Ace R9200 11/30t	Shimano Ultegra R8100 11/30t	Shimano 105 R7100 11/34T	Shimano Ultegra R8000 11/30t
Chain	Shimano M9100	Shimano M8100	Shimano M7100	Shimano Ultegra R8000
Wheelset	Fulcrum Wind DB	Fulcrum 600 DB	Fulcrum 600 DB	Fulcrum 600 DB
Tyres	Pirelli PZero Race 700x28	Vittoria Zaffiro pro 700x28	Vittoria Zaffiro pro 700x28	Vittoria Zaffiro pro 700x28
Saddle	Selle Italia Novus Boost	Selle Italia Model X	Selle Italia Model X	Selle Italia Model X

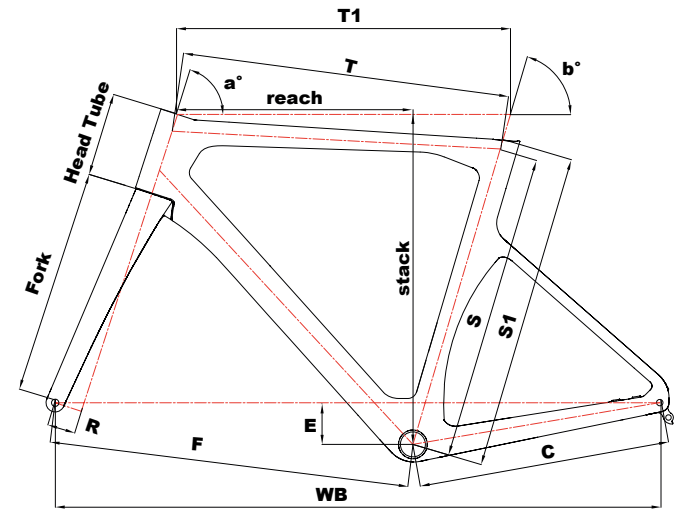

geometry

	S1	T1	H/T	A	B	R	C	F	WB	E	FORK	STACK	REACH
XS	450	519	112	71	74	50	406	582	978	70	373	512	372
S	480	537	123	71,5	73,5	50	406	592	988	70	373	524	382
M	510	555	138	71,8	73	50	408	600	998	70	373	540	389
L	540	572	158	72	72,5	50	408	610	1008	70	373	560	395
XL	570	590	180	72,7	72	50	408	619	1017	70	373	583	403

frame specs

Sizes	XS (45) - S (48) - M (51) - L (54) - XL (57)
Cockpit	/
Material	Columbus Carbon Monocoque
Headset	IS 52/28,6 IS 52/40
Seatpost	ø 27,2
Seat Clamp	Hidden (included)
BB Shell	Press Fit 86,5 x 41 mm
Ft. derailleur	Braze-On
Routing	Full Internal - Di2/EPS Compatible
Color	Triple White Slow Fade / Triple Grey Slow Fade / Midnight Scream
Tyre Clear.	up to 700x30 mm
Fork	Columbus Disc 1-1/2" Carbon Monocoque Internal Cable Routing
Weight	Frame 990g (size M) - Fork 420g (uncut)
Brake	Flat Mount Disc Brake, Rotor Size Up To 160 mm
Dropouts ST	Rear TA Ø 12x142mm - M12x162 / Front TA Ø 12x100mm - M12x120
Highlights	F-R Skewers

superstar

The Superstar is Cinelli's beloved carbon fiber re-interpretation of the Italian stage-racing bicycle that is the brand's heritage and DNA.





GRUPPO SPORTIVO TEAM

19

TEAM LIMITED

Pinarello

URSUS

URSUS

URSUS

URSUS

URSUS

URSUS

URSUS

URSUS

URSUS

URSUS

URSUS

URSUS

URSUS

URSUS

URSUS

QUINCE

COLUMBUS

AYUSO

EQUIPE

312

312

312

312

312

312

312

312

superstar

frame-kit - complete bike

- Beloved by riders for its smart mix of low-weight, aggressive handling over highly varied terrain and long-distance riding comfort
- Classic Italian grand tour geometry
- Shaped for maximum control and efficiency of carbon fiber lay up
- 12mm thru-axle



The Superstar is Cinelli's carbon fiber re-interpretation of the Italian stage-racing bicycle that is the brand's heritage and DNA. When developing the Superstar, Cinelli engineers studied how the inherent qualities of carbon fiber and its manufacturing processes could be employed to produce a contemporary iteration of the legendary versatility of the Italian Grand Tour ride quality i.e. the intelligent balance of low-weight, aggressive handling over highly varied terrain and long-distance riding comfort. In fact, owners of the Superstar will always tell you what they love most about the bike is its superlative ride quality!



specs

FRAME WEIGHT (M)	FORK WEIGHT (M)	PRESS FIT	MAX TYRE
1140 g	440 g	BB 86,5	28 mm

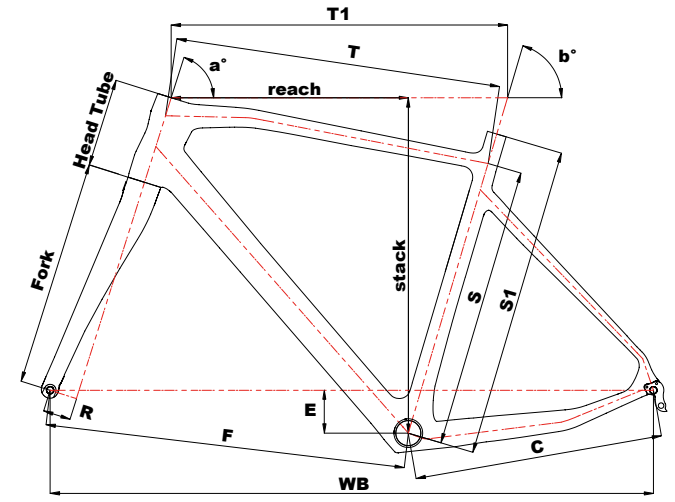

geometry

	S1	S	T1	T	H/T	A	B	R	C	F	WB	E	FORK	STACK	REACH
XS	460	407	515	500	110	71	75	45	415	577	982	70	368	509	373
S	480	430	533	517	120	72	74	45	415	581	987	70	368	522	383
M	510	460	550	533	145	72,5	73,5	45	415	590	995	70	368	548	387
L	540	498	566	550	160	73	73	45	415	595	1001	70	368	564	393
XL	570	523	585	568	185	73,5	72,5	45	415	604	1009	70	368	590	399

assembly

	ULTEGRA Di2 12v	105 Di2	ULTEGRA 11v
Drivetrain	Shimano Ultegra 8170	Shimano 105 7100	Shimano Ultegra 8020
Handlebar	Cinelli Vai	Cinelli Vai	Cinelli Vai
Stem	Cinelli Vai	Cinelli Vai	Cinelli Vai
Seatpost	Cinelli Vai Ø 27,2	Cinelli Vai Ø 27,2	Cinelli Vai Ø 27,2
Shifters	Shimano Ultegra R8170	Shimano 105 R7170	Shimano Ultegra R8020
Brakes	Shimano Ultegra R8170	Shimano 105 R7170	Shimano Ultegra R8070
Rotors	Shimano 160 - 140 mm	Shimano 160 - 140 mm	Shimano 160 - 140 mm
Ft. derailleur	Shimano Ultegra R8150	Shimano 105 R7150	Shimano Ultegra R8000
R. derailleur	Shimano Ultegra R8150	Shimano 105 R7150	Shimano Ultegra R8000
Crankset	Shimano Ultegra R8100 52/36t	Shimano 105 R7100 52/36T	Shimano Ultegra R8000 52/36t
Cassette	Shimano Ultegra R8100 11/30t	Shimano 105 R7100 11/34T	Shimano Ultegra R8000 11/30t
Chain	Shimano M8100	Shimano M7100	Shimano Ultegra R8000
Wheelset	Fulcrum 600 DB	Fulcrum 600 DB	Fulcrum 600 DB
Tyres	Vittoria Zaffiro pro 700x28	Vittoria Zaffiro pro 700x28	Vittoria Zaffiro pro 700x28
Saddle	Selle Italia Model X	Selle Italia Model X	Selle Italia Model X

frame specs

Sizes	XS (46) - S (48) - M (51) - L (54) - XL (57)
Material	Columbus Carbon Monocoque T700
Headset	IS 42/28,6 IS 52/40 Columbus Compass 1-1/2" incl.
Seatpost	Ø 27,2 mm
Seat Clamp	Ø 31,8 mm
BB Shell	Press Fit 86,5 x 41 mm
Ft. derailleur	Braze-On
Routing	Internal - Di2/EPS compatible
Color	Dark Night
Tyre Clear.	up to 700x28 mm
Fork	Columbus Futura Disc 1-1/8" 1-1/2" Carbon Monoc.
Weight	Frame 1140 g. (size M) Fork 440 g. (uncut)
Brake	Flat mount disc brake, rotor size up to 160mm
Dropouts ST	Rear TA Ø 12x142mm - M12x167 / Front TA Ø 12x100mm - M12x119
Highlights	Extra hanger / Di2 / EPS cable inserts / F-R Skewers

xcr

An ultra-light 100% Made in Italy steel racing frame that represents Cinelli's interpretation of the most important innovation steel bicycle manufacturing of the last 25 years: Columbus' XCR bi-phasic stainless steel.





xcr

frame-kit - complete bike

- **NEW:** Fully integrated cable routing with Columbus Trittico
- **NEW:** T47 bottom bracket
- Italian racing geometry
- Fastback hidden seat clamp
- Titanium CNC head badge
- Winged-C dropouts
- World's lightest steel tubeset



The XCR represents Cinelli's 100% Made in Italy interpretation of the most important technological steel bicycle manufacturing technology of the last 25 years: Columbus XCR bi-phasic stainless steel. Featuring Italian racing geometry, round oversized tubes (38.4mm downtube with oriented ellipses), disc brakes, titanium headbadge, fastback seat stays, handpolished mirror finish and a 1700g true frame weight: this is the only performance frame in the world that will also be raced by your children and grandchildren. The ultimate heirloom performance bike.

specs

FRAME WEIGHT (M)	FORK WEIGHT (M)	PRESS FIT	MAX TYRE
1700 g	430 g	T47	32 mm

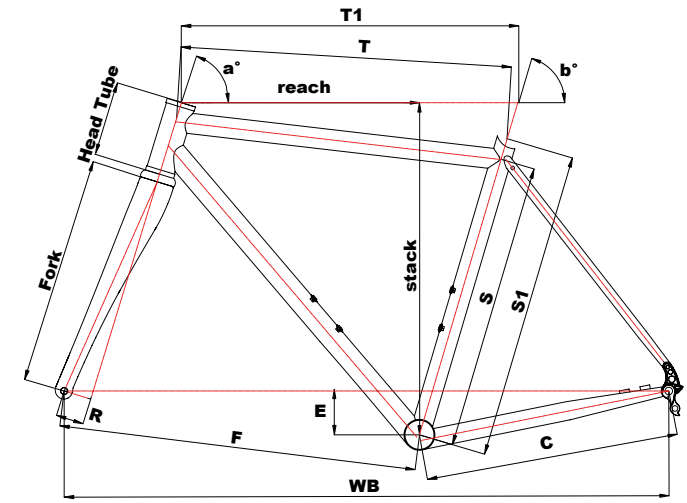

geometry

	S1	S	T1	T	H/T	A	B	R	C	F	WB	E	FORK	STACK	REACH
XS	450	415	515	498	98	71,5	74,5	45	410	570	967	73	368	491	378
S	480	435	525	509	104	72	74	45	410	572	971	73	368	498	382
M	500	465	545	530	121	73	73,5	45	410	579	979	71	368	516	390
L	530	495	560	544	139	73,5	73	45	415	583	989	71	368	535	396
XL	560	525	580	564	172	73,5	72,5	45	415	599	1005	68	368	560	403

assembly

	SUPER RECORD WRL	RED ETAP axs	DURA-ACE DISC DI2	ULTEGRA DISC DI2
Drivetrain	Campagnolo Super Record	Sram Red Etap AXS	Shimano Dura-Ace 9270	Shimano Ultegra 8170
Handlebar	Columbus Comp. Carbon Road	Columbus Comp. Carbon Road	Columbus Comp. Carbon Road	Columbus Comp. Carbon Road
Stem	Columbus Comp. Carbon Road	Columbus Comp. Carbon Road	Columbus Comp. Carbon Road	Columbus Comp. Carbon Road
Seatpost	Columbus Comp. Carbon Road	Columbus Comp. Carbon Road	Columbus Comp. Carbon Road	Columbus Comp. Carbon Road
Shifters	Campagnolo Super Record	Sram Red Etap AXS	Shimano Dura-Ace R9270	Shimano Ultegra R8170
Brakes	Campagnolo Super Record	Sram Red	Shimano Dura-Ace R9270	Shimano Ultegra R8170
Rotors	Campagnolo 160 - 140 mm	Sram Centerline XR 160 - 140 mm	Shimano 160 - 140 mm	Shimano 160 - 140 mm
Ft. derailleur	Campagnolo Super Record	Sram Red Etap AXS	Shimano Dura-Ace R9250	Shimano Ultegra R8150
R. derailleur	Campagnolo Super Record	Sram Red Etap AXS	Shimano Dura-Ace R9250	Shimano Ultegra R8150
Crankset	Campagnolo Super Record 48/32t	Sram Red Etap AXS 48/35t	Shimano Dura-Ace R9200 52/36t	Shimano Ultegra R8100 52/36t
Cassette	Campagnolo Super Record 10/29t	Sram Red Etap AXS 10/28t	Shimano Dura-Ace R9200 11/30t	Shimano Ultegra R8100 11/30t
Chain	Campagnolo Super Record	Sram Force Flathead	Shimano M9100	Shimano M8100
Wheelset	Campagnolo Hyperon	Fulcrum Wind DB	Fulcrum Wind DB	Fulcrum Wind DB
Tyres	Pirelli PZero 700x28	Pirelli PZero 700x28	Pirelli PZero 700x28	Pirelli PZero 700x28
Saddle	Selle Italia Novus	Selle Italia Novus	Selle Italia Novus	Selle Italia Novus

frame specs

Sizes	XS (45) - S (48) - M (50) - L (53) - XL (56) - Made to Measure
Material	Columbus Xcr Tubeset
Headset	ZS 44/28,6 EC 44/40
Seatpost	Ø 31,6 mm
Seat Clamp	Integrated
BB Shell	T47 68 mm
Ft. derailleur	Clamp Ø 33 mm
Routing	Internal - Electronic Only
Color	Magic Mirror
Tyre Clear.	up to 700x32 mm
Fork	Columbus Trittico Carbon Road
Weight	Frame 1700 g. (size M) Fork 430 g. (uncut)
Brake	Flat Mount Disc Brake, rotor size up to 160 mm
Dropouts ST	Rear TA Ø 12x142mm - M12x173 / Front TA Ø 12x100mm - M12x119
Highlights	Frame / Fork / Ft. Derailleur Clamp

xcr rim

The Xcr represents Cinelli's interpretation of the most important technological steel bicycle manufacturing technology of the last 25 years: Columbus XCr bi-phasic stainless steel.





xcr rim

frame-kit - complete bike

- Italian racing geometry
- Fastback hidden seat clamp
- Titanium CNC head badge
- Winged-C dropouts
- World's lightest steel tubeset



100% made in Italy from Columbus XCr stainless steel tubing and featuring Italian racing geometry, round oversized tubes (38.4mm downtube with oriented ellipses), rim brakes, titanium headbadge, fastback seat stays, handpolished mirror finish and a 1700g true frame weight, Cinelli XCr is the only performance frame in the world that will continue to be raced by your children and grandchildren.



specs

FRAME WEIGHT (M)	FORK WEIGHT (M)	BOTTOM BRACKET	MAX TYRE
1650 g	350 g	BSA	28 mm

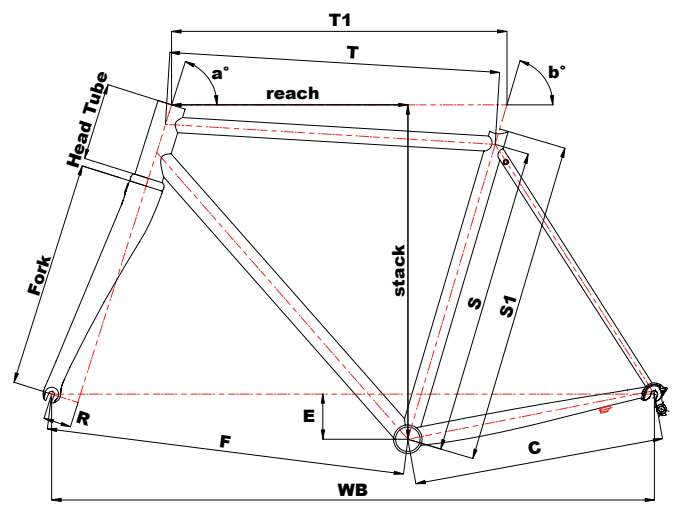

geometry

	S1	S	T1	T	H/T	A	B	R	C	F	WB	E	FORK	STACK	REACH
XS	450	415	515	498	98	71,5	74,5	45	403	570	962	73	368	491	378
S	480	435	525	509	104	72	74	45	405	572	966	73	368	498	382
M	500	465	545	530	121	73	73,5	45	405	579	974	71	368	516	390
L	530	495	560	544	139	73,5	73	45	408	583	981	71	368	535	396
XL	560	525	580	564	172	73,5	72,5	45	408	599	997	68	368	560	403

assembly

	ULTEGRA 11v
Drivetrain	Ultegra 8000
Handlebar	Cinelli Vai
Stem	Cinelli Vai
Seatpost	Cinelli Vai Ø 31,6
Shifters	Shimano Ultegra 8000
Brakes	Shimano Ultegra 8000
Rotors	/
Ft. derailleur	Shimano Ultegra 8000
R. derailleur	Shimano Ultegra 8000
Crankset	Shimano Ultegra 8000 52/36t
Cassette	Shimano Ultegra 8000 11/30t
Chain	Shimano HG701-11
Wheelset	Fulcrum 600
Tyres	Vittoria Zaffiro pro 700x28
Saddle	Selle Italia Model X



frame specs

Sizes	XS (45) - S (48) - M (50) - L (53) - XL (56) - Made to Measure
Material	Columbus Xcr Tubeset
Headset	ZS 44/28,6 EC 44/40
Seatpost	Ø 31,6 mm
Seat Clamp	Integrated
BB Shell	BSA 68 mm
Ft. derailleur	Clamp Ø 33 mm
Routing	External
Color	Magic Mirror
Tyre Clear.	up to 700x28 mm
Fork	Columbus Futura Caliper 1-1/8" - 1-1/2" Carbon Monocoque
Weight	Frame 1700 g. (size M) Fork 350 g. (uncut)
Brake	Standard Rim Brake
Dropouts ST	Front QR 100 mm - Rear QR 130 mm
Highlights	Frame / Fork / Ft. Derailleur Clamp

nemo tig road

Cinelli's 100% Made in Milano steel road flagship hybridizes heritage with contemporary performance to create a new icon of Il Grande Ciclismo.



SPECIAL COLORS ONLY GLOSSY FINISH

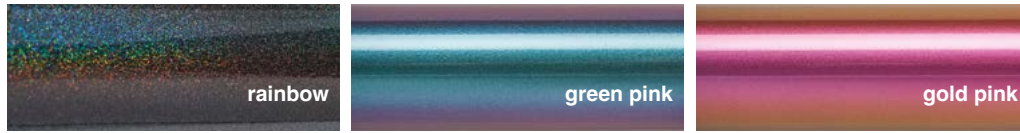

FACTORY COLORS GLOSSY OR MATT FINISH FINISH



Every Cinelli Nemo Tig Model (road disc and rim, gravel and allroad) is available in 69 paint colour and matt or finishes, including three special colorways.

nemo tig road

frame-kit - complete bike

- **NEW:** T47 bottom bracket allows for full internal cable routing (including Columbus Trittico cockpit) as well as improved stiffness
- **NEW:** Ultralight CNC aluminium seatpost collar reduces weight and improves product life
- **NEW:** seatpost tube and diameter reduces weight and improves comfort
- **NEW:** As of March 2023 all Nemo frames are manufactured within the Cinelli Milan HQ by our internal framebuilder allowing us to create the world's shortest supply chain for premium road bikes.
- **NEW:** Lasercut minimalist brake bridge for further weight savings
- **NEW:** Geometry
- Custom drawn Columbus Spirit triple-butted tubes
- Classic Italian racing geometry
- Design-driven detailing and finish
- Available in 69 different paint and finish options



specs

FRAME WEIGHT (M)	FORK WEIGHT (M)	BOTTOM BRACKET	MAX TYRE
2000 g	430 g	T47	28 mm

The Nemo is Cinelli's flagship steel road bike, handcraft to hybridize our more than 75 years of Italian cycling heritage with the performance possibilities of contemporary cold-drawn steel tubing technology. Every Nemo frame is handwelded by Cinelli's internal framebuilder in its Milanese HQ, using custom drawn triple butted tube drawn by its sister company Columbus, less than 100 metres from the framebuilder creating the world's shortest performance bicycle supply chain.

For 2024 – thanks to continuous three-way dialogue between the Cinelli design office, our framebuilder and Columbus – the Nemo has undergone subtle but significant manufacturing improvements including a 170g weight reduction (size Medium), the introduction of the T47 bottom bracket allowing for fully-internal cable routing as well as improving stiffness and a new ultralight CNC'd aluminium seatpost collar.

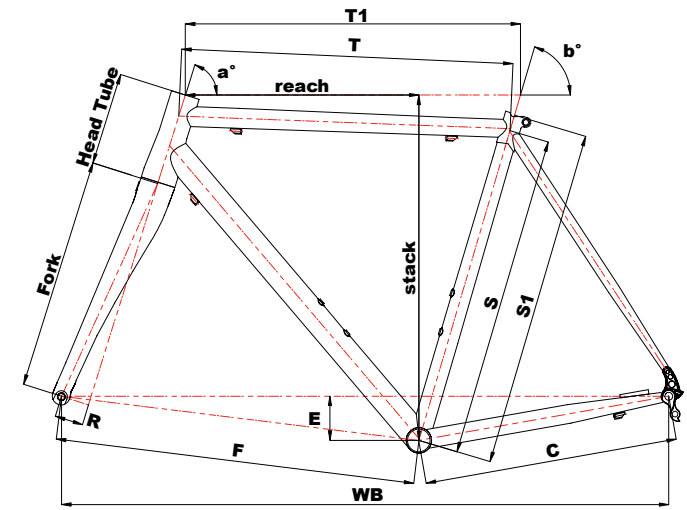

geometry

	S1	T1	H/T	A	B	R	C	F	WB	E	FORK	STACK	REACH
XS	480	510	110	71	74,5	45	410	572	972	70	368	509	369
S	510	525	130	71,5	74	45	410	579	978	70	368	530	373
M	540	545	145	72,5	73,5	45	410	585	985	70	368	548	383
L	560	555	165	73	73,5	45	410	590	990	70	368	568	387
XL	590	575	185	73	73	45	415	605	1010	70	368	588	395
XXL	610	590	210	73,5	73	45	415	614	1019	70	368	613	402

assembly

	RED ETAP axs	DURA-ACE DISC DI2	ULTEGRA DISC DI2	ULTEGRA DISC 11v	105 DISC DI2
Drivetrain	Sram Red Etap AXS	Shimano Dura-Ace 9270	Shimano Ultegra 8170	Shimano Ultegra 8020	Shimano 105 7100
Handlebar	Columbus Comp. Carbon Road	Columbus Comp. Carbon Road	Cinelli Vai	Cinelli Vai	Cinelli Vai
Stem	Columbus Comp. Carbon Road	Columbus Comp. Carbon Road	Cinelli Vai	Cinelli Vai	Cinelli Vai
Seatpost	Columbus Comp. Carbon Road	Columbus Comp. Carbon Road	Cinelli Vai Ø 27,2	Cinelli Vai Ø 27,2	Cinelli Vai Ø 27,2
Shifters	Sram Red Etap AXS	Shimano Dura-Ace R9270	Shimano Ultegra R8170	Shimano Ultegra R8020	Shimano 105 R7170
Brakes	Sram Red	Shimano Dura-Ace R9270	Shimano Ultegra R8170	Shimano Ultegra R8070	Shimano 105 R7170
Rotors	Sram Centerline XR 160 - 140 mm	Shimano 160 - 140 mm	Shimano 160 - 140 mm	Shimano 160 - 140 mm	Shimano 160 - 140 mm
Ft. derailleur	Sram Red Etap AXS	Shimano Dura-Ace R9250	Shimano Ultegra R8150	Shimano Ultegra R8000	Shimano 105 R7150
R. derailleur	Sram Red Etap AXS	Shimano Dura-Ace R9250	Shimano Ultegra R8150	Shimano Ultegra R8000	Shimano 105 R7150
Crankset	Sram Red Etap AXS 48/35t	Shimano Dura-Ace R9200 52/36t	Shimano Ultegra R8100 52/36t	Shimano Ultegra R8000 52/36t	Shimano 105 R7100 50/34
Cassette	Sram Red Etap AXS 10/28t	Shimano Dura-Ace R9200 11/30t	Shimano Ultegra R8100 11/30t	Shimano Ultegra R8000 11/30t	Shimano 105 R7100 11/34T
Chain	Sram Red Flathead	Shimano M9100	Shimano M8100	Shimano Ultegra 8000	Shimano M7100
Wheelset	Fulcrum Wind DB	Fulcrum Wind DB	Fulcrum 600 DB	Fulcrum 600 DB	Fulcrum 600 DB
Tyres	Pirelli PZero 700x28	Pirelli PZero 700x28	Vittoria Zaffiro pro 700x28	Vittoria Zaffiro pro 700x28	Vittoria Zaffiro pro 700x28
Saddle	Selle Italia Novus	Selle Italia Novus	Selle Italia Model X	Selle Italia Model X	Selle Italia Model X

frame specs

Sizes	XS (48) - S (51) - M (54) - L (56) - XL (59) - XXL (61) / Made to Measure
Material	Columbus Spirit HSS Tubaset
Headset	IS 42/28,6 IS 52/40
Seatpost	Ø 27,2 mm
Seat Clamp	CNC Machined ø 29,8
BB Shell	T47 68 mm
Ft. derailleur	Clamp Ø 28,6 mm
Routing	Full Internal (Red, Dura-Ace) - External / Internal Hydraulic Disc Brake Housing
Color	Orange Blossom Special (+3 Custom colors and +33 Colors matt or glossy)
Tyre Clear.	up to 700x28 mm
Fork	Columbus Components (Red - Dura-Ace) - Columbus Trittico Carbon Road
Weight	Frame 2000 g. (size M) Fork 430 g. (uncut)
Brake	Flat Mount Disc Brake, rotor size up to 160 mm
Dropouts ST	Rear TA Ø 12x142mm - M12x173 / Front TA Ø 12x100mm - M12x119
Highlights	Frame / Fork / Ft. Derailleur Clamp / Ft. & Re. Skewers / Headset

nemo tig road rim

Cinelli's 100% Made in Milano steel road flagship hybridizes heritage with contemporary performance to create a new icon of Il Grande Ciclismo.





nemo tig road rim

frame-kit - complete bike

- Custom drawn Columbus Spirit triple-butted tubes
- Classic Italian racing geometry
- Design-driven detailing and finish
- Available in 69 different paint and finish options



specs

FRAME WEIGHT (M)	FORK WEIGHT (M)	BOTTOM BRACKET	MAX TYRE
1800 g	350 g	BSA	28 mm

The Nemo is Cinelli's flagship steel road bike, handcraft to hybridize our more than 75 years of Italian cycling heritage with the performance possibilities of contemporary cold-drawn steel tubing technology. Every Nemo frame is handwelded by Cinelli's internal framebuilder in its Milanese HQ, using custom drawn triple butted tube drawn by its sister company Columbus, less than 100 metres from the framebuilder creating the world's shortest performance bicycle supply chain.

For 2024 – thanks to continuous three-way dialogue between the Cinelli design office, our framebuilder and Columbus – the Nemo has undergone subtle but significant manufacturing improvements including a 170g weight reduction (size Medium), the introduction of the T47 bottom bracket allowing for fully-internal cable routing as well as improving stiffness and a new ultralight CNC'd aluminium seatpost collar.

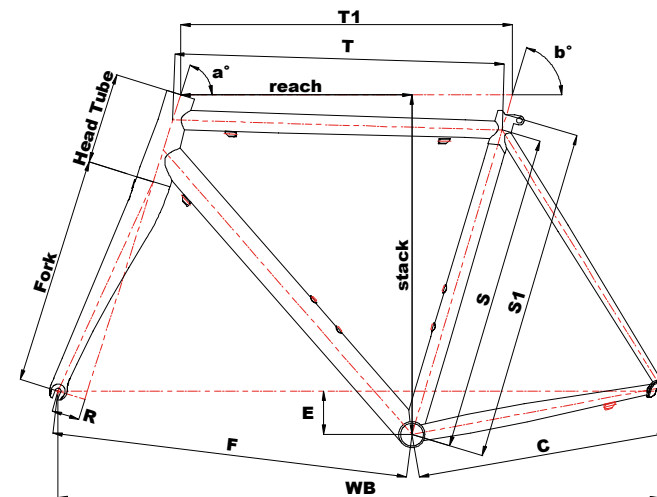

geometry

	S1	S	T1	T	H/T	A	B	R	C	F	WB	E	FORK	STACK	REACH
XS	480	455	510	506	110	71	74,5	45	405	572	967	70	368	510	369
S	510	485	520	516	120	71,5	74	45	405	573	968	70	368	520	371
M	540	515	535	531	145	72,5	73,5	45	405	575	969	70	368	547	373
L	560	535	550	545	160	73	73,5	45	405	585	980	70	368	564	383
XL	590	565	575	570	185	73	73	45	408	605	1003	70	368	587	395
XXL	610	585	590	584	210	73,5	72,5	45	410	609	1005	70	368	613	397

assembly

	ULTEGRA 11v
Drivetrain	Shimano Ultegra 8000
Handlebar	Cinelli Vai
Stem	Cinelli Vai
Seatpost	Cinelli Vai Ø 27,2
Shifters	Shimano Ultegra R8000
Brakes	Shimano Ultegra R8000
Rotors	/
Ft. derailleur	Shimano Ultegra R8000
R. derailleur	Shimano Ultegra R8000
Crankset	Shimano Ultegra R8000 52/36t
Cassette	Shimano Ultegra R8000 11/30t
Chain	Shimano Ultegra R8000
Wheelset	Fulcrum Racing 600
Tyres	Vittoria Zaffiro pro 700x28
Saddle	Selle Italia Model X



frame specs

Sizes	XS (48) - S (51) - M (54) - L (56) - XL (59) - XXL (61) / Made to Measure
Material	Columbus Spirit HSS Tubeset
Headset	IS 42/28,6 IS 52/40
Seatpost	Ø 27,2 mm
Seat Clamp	Integrated
BB Shell	BSA 68 mm / Press Fit 86,5 x 41 (Custom)
Ft. derailleur	Clamp Ø 31,7 mm
Routing	External
Color	Racing Red (+3 Custom colors and +33 Colors matt or glossy)
Tyre Clear.	up to 700x28 mm
Fork	Columbus Futura Caliper 1-1/8" - 1-1/2" Carbon Monoc.
Weight	Frame 1800 g. (size M) Fork 350 g. (uncut)
Brake	Standard Rim Brake
Dropouts ST	Front QR 100 mm - Rear QR 130 mm
Highlights	Frame / Fork / Ft. Derailleur Clamp / Headset

nemo tig allroad

The ultimate go-everywhere
100% Made in Milano
endurance steel machine.





Pentel EnerGel

Q77
S11

NOTICE
7 YEAR
WARRANTY

COLUMBIA

nemo tig allroad

frame-kit - complete bike

- **NEW:** Allroad geometry including (sz M) 150mm headtube, 72,5° ST angle, 1018mm wheel base and 35mm wheel clearance for a more endurance position, handling and multi-terrain capability.
- **NEW:** As of March 2023 all Nemo frames are manufactured within the Cinelli Milan HQ by our internal framebuilder allowing us to create the world's shortest supply chain for premium road bikes.
- **NEW:** Ultralight collar
- Custom drawn Columbus Spirit triple-butted tubes
- Design-driven detailing and finish
- Available in 69 different paint and finish options



specs

FRAME WEIGHT (M)	FORK WEIGHT (M)	BOTTOM BRACKET	MAX TYRE
2000 g	450 g	BSA	35 mm

The Nemo All Road is entirely handcrafted by Cinelli's internal framebuilder in its Milanese HQ using custom drawn triple butted tube drawn by its sister company Columbus, less than 100 metres from the framebuilder creating the world's shortest performance bicycle supply chain.

Representing an evolution in the way road bikes – particularly contemporary oversized steel tube bikes – are being ridden as pleasure, adventure, exploration of nature and oneself become ever more important for the evolved cyclist, the Nemo All Road has been fine tuned for maximum comfort on epic rides and a geometry and handling that is equally at home on asphalt and dirt. Experienced cyclists will in fact notice carefully chosen details such as (sz M) the 150mm headtube, 72,5° ST angle, 1018mm wheel base and 35mm wheel clearance as well as the legendary ride feel provided by an artisanally hand welded frame made from custom drawn Columbus Spirit triple-butted tubes. A true forever (and anywhere) Cinelli.

**READY TO SHIP COLOUR:
OLIVE GREEN, GLOSSY FINISH, WHITE DECALS.**



assembly

	ULTEGRA Di2	105 Di2	ULTEGRA 11v
Drivetrain	Shimano Ultegra 8170	Shimano 105 7100	Shimano Ultegra 8020
Handlebar	Cinelli Vai	Cinelli Vai	Cinelli Vai
Stem	Cinelli Vai	Cinelli Vai	Cinelli Vai
Seatpost	Cinelli Vai Ø 27,2	Cinelli Vai Ø 27,2	Cinelli Vai Ø 27,2
Shifters	Shimano Ultegra R8170	Shimano 105 R7170	Shimano Ultegra R8020
Brakes	Shimano Ultegra R8170	Shimano 105 R7170	Shimano Ultegra R8070
Rotors	Shimano 160 - 140 mm	Shimano 160 - 140 mm	Shimano 160 - 140 mm
Ft. derailleur	Shimano Ultegra R8150	Shimano 105 R7150	Shimano Ultegra R8000
R. derailleur	Shimano Ultegra R8150	Shimano 105 R7150	Shimano Ultegra R8000
Crankset	Shimano Ultegra R8100 52/36t	Shimano 105 R7100 52/36T	Shimano Ultegra R8000 52/36t
Cassette	Shimano Ultegra R8100 11/30t	Shimano 105 R7100 11/34T	Shimano Ultegra R8000 11/30t
Chain	Shimano M8100	Shimano M7100	Shimano Ultegra R8000
Wheelset	Fulcrum Rapid Red 5	Fulcrum Rapid Red 5	Fulcrum Rapid Red 5
Tyres	Vittoria Corsa Next 700x34	Vittoria Corsa Next 700x34	Vittoria Corsa Next 700x34
Saddle	SSM Shortfit	SSM Shortfit	SSM Shortfit

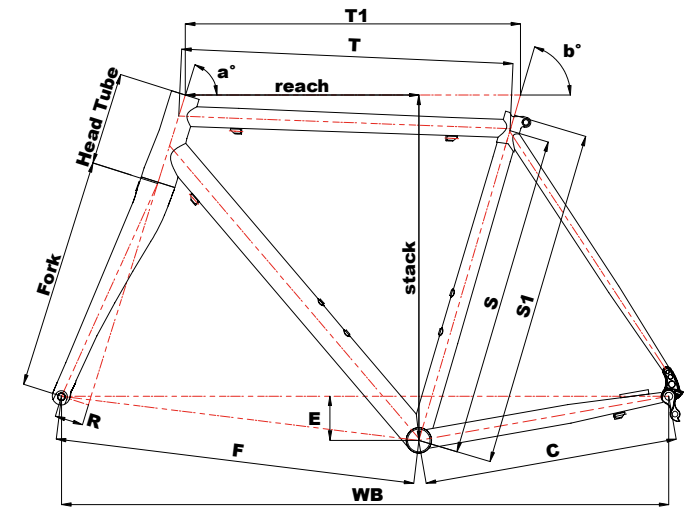

geometry

	S1	T1	H/T	A	B	R	C	F	WB	E	FORK	STACK	REACH
XS	480	510	115	70	74,5	47	430	584	1005	68	382	521	366
S	510	520	135	70	74,5	47	430	596	1017	68	382	540	370
M	540	535	150	71	74	47	430	597	1018	68	382	557	375
L	560	555	175	72	73,5	47	430	603	1024	68	382	585	382
XL	590	575	200	72,5	73	47	430	613	1033	68	382	611	388
XXL	610	595	225	73	72,5	47	430	621	1042	68	382	637	394

frame specs

Sizes	XS (48) - S (51) - M (54) - L (56) - XL (59) - XXL (61) / Made to Measure
Material	Columbus Spirit HSS Tubaset
Headset	IS 42/28,6 IS 47/33
Seatpost	Ø 27,2 mm
Seat Clamp	CNC Machined ø 29,8
BB Shell	BSA 68 mm
Ft. derailleur	Clamp Ø 28,6mm
Routing	External / Internal Hydraulic Disc Brake Housing
Color	Olive Green (+3 Custom colors and +33 Colors matt or glossy)
Tyre Clear.	up to 700x35 mm
Fork	Columbus Futura Allroad Disc 1-1/8" - 1-1/4" Carbon Monoc.
Weight	Frame 2000 g. (size M) Fork 450 g. (uncut)
Brake	Flat Mount Disc Brake, rotor size up to 160 mm
Dropouts ST	Rear TA Ø 12x142mm - M12x173 / Front TA Ø 12x100mm - M12x119
Highlights	Frame / Fork / Ft. Derailleur Clamp / Ft. & Re. Skewers / Headset

supercorsa

The world's most famous classic Italian road bike, in uninterrupted production since the early 1950s.





supercorsa

frame-kit

- The ultimate classic Italian road bike, In uninterrupted production since the early 1950s
- 100% Made in Italy from Italian materials
- Still manufactured according the original specifications perfected by Cino Cinelli during the 1950s
- Available in 17 sizes and 8 colours



Available colors:



BIANCO PERLA



AZZURRO LASER



TITANIUM GREY



VERDE JAGUAR



BLACK TIE



BLU CHINA



GIALLO CURRY



ROSSO FERRARI



specs

FRAME WEIGHT (M)	FORK WEIGHT (M)	BOTTOM BRACKET	MAX TYRE
1830 g	670 g	ITA	25 mm

The Cinelli Supercorsa is the world's most iconic steel bicycle frame and has been in uninterrupted production for almost 70 years. The first Supercorsa was designed by Cino Cinelli, together with his framebuilder Luigi Valsassina in the early 1950s. His stated goal was "the perfect functional harmony between the three main parts of the frame: the fork, the main triangle and the rear stays." This harmony was to be achieved through the development of stiffness, elasticity, aerodynamics and aesthetics, with each component of the frame completely redesigned according to the radical criteria of Cino, the stubborn perfectionist. After 15 years experimenting with and refining what he described as the most "philosophical" piece of equipment produced by his brand, Cino and Valsassina arrived at the iconic solutions still so clearly recognizable in today's Supercorsa: the proprietary sloping fork crown, the double-bolt fastback seat stays, pointed lugs and perfect Italian stage racing geometry. Since then – the mid-1960s – the frame has undergone only two significant modifications: a new graphic system for the frame designed by Milanese legened Italo Lupi in 1979 to complement the introduction of his "winged-C" Cinelli logo and, in 1984, the introduction of the Cinelli Spoiler bottom bracket, the only die-cast bicycle frame part to ever be granted a patent. All other modifications to the frame have regarded subtle and "under-the-bonnet" technological updates of steel materials and manufacturing techniques, allowing for the original ride quality and aesthetic of the Supercorsa to remain respectfully unchanged.

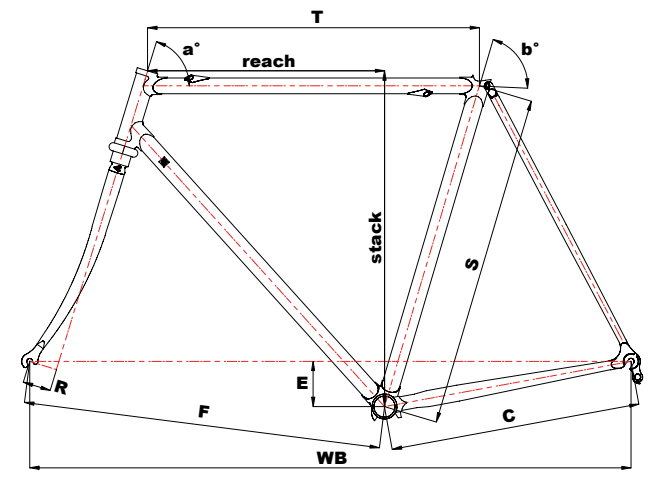

frame specs

Sizes	48 to 64 (1 cm) - Made to Measure
Material	Columbus SL Double Butted Tubeset
Headset	EC 30/25,4-24TPI EC 30/26
Seatpost	Ø 27,2 mm
Seat Clamp	Integrated
BB Shell	ITA 70 mm
Ft. derailleur	Braze-On
Routing	Rear Brake Internal Routing -Downtube Shifter Bosses
Color	Rosso Ferrari-Bianco Perla-Azzurro Laser-Titanium Grey-Verde Jaguar-Black Tie-Blu China-Giallo Curry
Tyre Clear.	up to 700x25 mm
Fork	Columbus SL 1" Threaded
Weight	Frame 1830 g. (size M) Fork 670 g. (uncut)
Brake	Standard Rim Brake
Dropouts ST	Front QR 100 mm - Rear QR 130 mm
Highlights	Frame / Fork

geometry

	T	A	B	R	C	F	WB	E	STACK	REACH
48	510	72	74,5	50	401	557	984,5	66	486	374
49	515	72	74,5	50	402	571	963	69	495	377
50	520	72,5	74,5	50	402	573,2	964,5	70	505	379
51	525	72,5	74	50	402	573,2	964	73	513	377
52	535	72,5	74	50	403	583	975	73	523	384
53	540	73	74	45	405	579	972,5	73	533	387
54	545	73	73,5	45	405	579,3	973	73	541	383
55	550	73	73,5	45	405	584	978	73	550	387
56	560	73	73,5	45	405	594	988	73	560	394
57	565	73	73,5	45	406	599	994	73	570	396
58	570	73	73	45	407	599,5	995	73	578	393
59	575	73	73	45	408	604	1001	73	587	396
60	580	73	73	45	409	609	1007	73	597	398
61	580	73	73	45	409	609	1007	73	606	395
62	590	73	73	45	409	619	1017	73	616	402
63	590	73	73	45	410	619	1018	73	626	399
64	595	73	73	45	410	620	1019	73	635	401

king zydeco

A pioneer of the European gravel riding movement, the King Zydeco is our go-fast-everywhere monocoque carbon fiber frame.





king zydeco

frame-kit - complete bike

- Performance gravel geometry
- Tyre clearance up to 700x47c or 650x2.1"
- Adaptive geometry thanks to Columbus fork dropouts that allow to change the rake from 47 to 52 mm
- Double response stiffness/compliance frame design for best off-road riding experience
- Downtube kevlar shield
- Bike packing ready rivet system



A pioneer of the European gravel riding movement, the King Zydeco is a go-fast-everywhere monocoque carbon fiber frame, perfect for competitive gravel riding and fast touring/endurance racing.

The engineering heart of the frame lies in the mould's transition between top tube and seat stays, specifically developed to allow for fibers to be continuously aligned allowing for significant weight reduction, optimization of the lay up and above all superior distribution of vibration arriving from the rear wheel.

Working in tandem with the oversized tube sections of the down and head tube a "double response system" of finely tuned stiffness and compliance is created. The emotional heart of the frame lies in exploring new attitudes and emotions on adventures you didn't previously think were possible!



specs

FRAME WEIGHT (M)	FORK WEIGHT (M)	BOTTOM BRACKET	MAX TYRE
1000 g	550 g	BB 386	700x47c 650bx2,1"

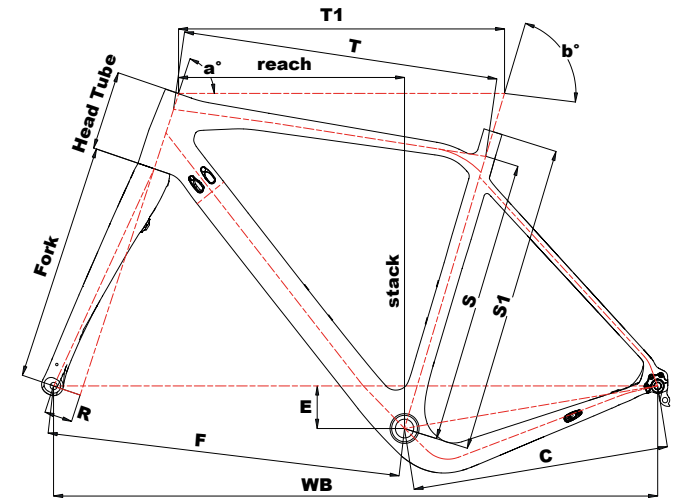

geometry

	S1	S	T1	T	H/T	A	B	R	C	F	WB	E	FORK	STACK	REACH
S	480	435	530	513	100	70	73	47/52	430	588	1010	70	395	519	371
M	510	468	550	530	130	71,5	73	47/52	430	595	1018	70	395	550	380
L	530	493	570	550	150	72,5	72,5	47/52	430	602	1024	70	395	576	389
XL	550	506	590	568	175	72,5	72,5	47/52	430	621	1044	70	395	599	400

assembly

	EKAR	RIVAL axS XPLR	GRX	GRX 1X MIX	ULTEGRA 11v
Drivetrain	Campagnolo Ekar	Sram Rival AXS XPLR	Shimano GRX	Shimano GRX	Shimano Ultegra 8020
Handlebar	Cinelli Swamp	Cinelli Swamp	Cinelli Swamp	Cinelli Alu 6061	Cinelli Swamp
Stem	Cinelli Vai	Cinelli Vai	Cinelli Vai	Cinelli Alu 6061	Cinelli Vai
Seatpost	Cinelli Vai Ø 27,2	Cinelli Vai Ø 27,2	Cinelli Vai Ø 27,2	Cinelli Alu 6061	Cinelli Vai Ø 27,2
Shifters	Campagnolo Ekar	Sram Rival AXS	Shimano GRX	Shimano GRX ST-RX600	Shimano Ultegra R8020 Disc
Brakes	Campagnolo Ekar	Sram Rival Hydro Disc	Shimano GRX	Shimano GRX ST-RX400	Shimano Ultegra R8070 Flat Mount
Rotors	Campagnolo Ekar	Paceline 160 mm	Shimano MT-800 160 mm	Shimano SM-RT64 160mm	Shimano 160 mm front - 160 mm rear
Ft. derailleur	/	/	/	/	Shimano Ultegra R8000
R. derailleur	Campagnolo Ekar	Sram Rival AXS XPLR	Shimano GRX	Shimano RD-RX812	Shimano Ultegra R8000
Crankset	Campagnolo Ekar 40T	Sram Rival 1 Wide 40t	Shimano GRX 40T	Shimano GRX FC-RX810-1 42T	Shimano Ultegra R8000 46/36t
Cassette	Campagnolo Ekar 9-42T	Sram Rival XPLR 10/44t	Shimano GRX	CS-M7000 SLX 11-42T	Shimano Ultegra R8000 11/32t
Chain	Campagnolo Ekar	Sram Rival	Shimano	KMC X11 EPT	Shimano Ultegra R8000
Wheelset	Fulcrum Rapid Red 500 DB	Fulcrum Rapid Red 500 DB	Fulcrum Rapid Red 500 DB	Fulcrum Rapid Red 900 DB	Fulcrum Rapid Red 500 DB
Tyres	Pirelli Cinturato H 700x40	Pirelli Cinturato H 700x40	Pirelli Cinturato H 700x40	WTB Riddler 700x37 Tan Sidewall	Pirelli Cinturato H 700x40
Saddle	SSM Shortfit	SSM Shortfit	SSM Shortfit	SSM Shortfit	SSM Shortfit

frame specs

Sizes	S (48) - M (51) - L (53) - XL (55)
Material	Columbus Carbon Monocoque
Headset	IS 42/28,6 IS 52/40 Columbus Compass 1-1/2" (Included)
Seatpost	Ø 27,2 mm
Seat Clamp	Ø 31,8 mm (Included)
BB Shell	BB386EVO 86,5 x 46 mm
Ft. derailleur	Clamp Ø 31,8 mm
Routing	Internal - Di2/EPS Compatible
Color	Gumbo - Grey Rock
Tyre Clear.	up to 700x47 C / 27,5x2.1 inc
Fork	Columbus Futura Cross 1-1/8" - 1-1/2" Carbon Monoc.
Weight	Frame 1000 g. (size M) Fork 550 g. (uncut)
Brake	Flat Mount Disc Brake, rotor size up to 160 mm
Dropouts ST	Rear TA Ø 12x142mm - M12x167 / Front TA Ø 12x100mm - M12x132
Highlights	Extra Hanger / Di2 - EPS Cable Insert / Ft. & Re. Skewers

zydeco

Our original gravel bike, loved by riders across the world for its lightweight performance feeling combined with ultra-versatile design details making it ready for both city and mud!





zydeco

frame-kit - complete bike

- Our original gravel bike
- Oversized triple-butted Columbus Zona aluminium tubing
- All-weather urban commute to performance gravel adventure versatility
- Custom rivet system allows user endless bag and rack options
- Max tyre clearance 700x40c
- 10,3kg total bike weight



The most beloved of all Cinelli gravel bikes, the Zydeco's appeal lies in the quality of its manufacturing (triple-butted Columbus Zonal aluminium tubes) and finish as well as its absolute versatility. Beyond its primary function as a performance gravel bike, the Zydeco can quickly morph into a bike-packing vehicle or fast all-weather urban commuter thanks to its exhaustive system of rivets.

specs

BIKE WEIGHT **10,3 Kg** BOTTOM BRACKET **BSA** MAX TYRE **40 mm**

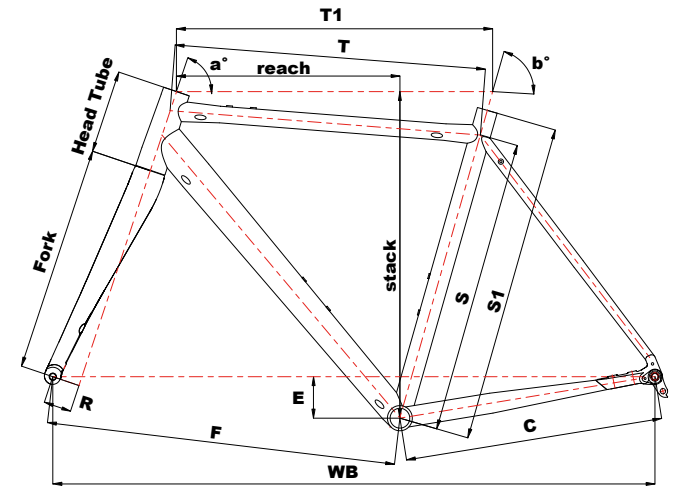

geometry

	S1	S	T1	T	H/T	A	B	R	C	F	WB	E	FORK	STACK	REACH
XS	490	447	510	504	100	70,5	74,5	47	440	580	1010	71	382	510	371
S	510	467	520	514	120	71	74,5	47	440	587	1017	70	382	530	375
M	540	497	539	530	140	71,5	74	47	440	595	1025	70	382	551	380
L	560	517	560	549	160	72	73,5	47	440	606	1037	70	382	572	390
XL	590	547	580	570	180	72,5	73	47	440	617	1047	70	382	592	399

assembly

GRX 2X10 MIX

Drivetrain	Shimano GRX
Handlebar	Cinelli Handlebar 6061
Stem	Cinelli Stem 6061
Seatpost	Cinelli Seat Post 6061 Ø 31,6
Shifters	Shimano GRX ST-RX400
Brakes	Shimano GRX BR-RX400
Rotors	Shimano SM-RT64 160 mm
Ft. derailleur	Shimano GRX FD-RX400
R. derailleur	Shimano GRX RD-RX400
Crankset	Shimano GRX FC-RX600 46/30
Cassette	Shimano CS-HG500-10 / 10 Speed / 11-34t
Chain	KMC X10
Wheelset	WTB ST i19 TCS2.0 Shimano Hub (RS-470) front & rear
Tyres	WTB Riddler 700x37c Tan Sidewall
Saddle	Cinelli SSM RND



frame specs

Sizes	XS (49) - S (51) - M (54) - L (56) - XL (59)
Material	Columbus Zonal Triple Butted Alloy
Headset	IS 42/28,6 IS 47/33
Seatpost	Ø 31,6 mm
Seat Clamp	Ø 34,9 mm
BB Shell	BSA 68 mm
Ft. derailleur	Clamp Ø 34,9 mm
Routing	Internal
Color	Muddy Dry
Tyre Clear.	up to 700x40 mm
Fork	Columbus Futura Allroad 1-1/8" - 1-1/4" Carbon Monocoque
Weight	Frame 1760 g. (size M) Fork 450 g. (uncut)
Brake	Flat Mount, Rotor Size Up to 160 mm
Dropouts ST	Rear TA Ø 12x142mm - M12x165 / Front TA Ø 12x100mm - M12x119
Highlights	Front & Rear Fenders Ready / Rear Rack Eyelets / Fast Fuel Eyelets

zydeco lala

Member of the Zydeco Gravel family, made to the same exacting standards as the original.



TV



zydeco lala

frame-kit - complete bike

- Oversized Columbus Zonal triple-buttet aluminium tubes
- Columbus Futura All Road carbon monocoque 1-1/4" fork
- Flat mount disc brakes & thru axle
- Bike-packing ready bag mounts on top tube and seat stays
- 700c x 40mm max tyre clearance



Zydeco LaLa is the newest member of the Zydeco gravel family. The frame is made to the same exceptional standards of the Zydeco with triple butted Columbus Zonal aluminium tubes, Columbus Futura All Road carbon monocoque 1-1/4" fork and flat mount disc brakes whilst the Shimano Sora groupset offers best performance value to money for riders looking to get on a new bike without further delay!

specs

BIKE WEIGHT	BOTTOM BRACKET	MAX TYRE
10,9 Kg	BSA	40 mm

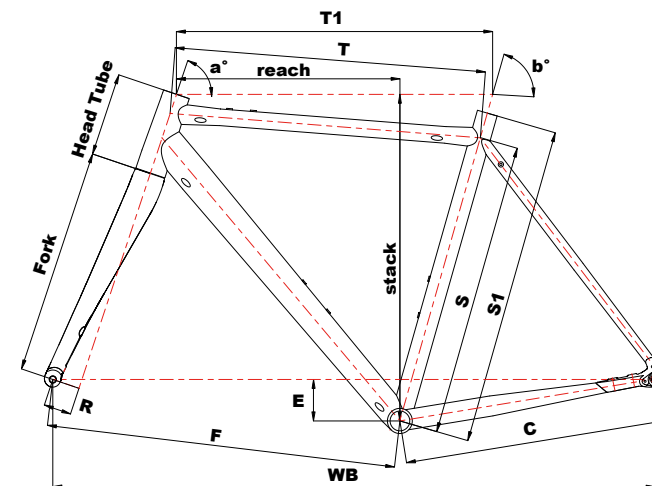

geometry

	S1	S	T1	T	H/T	A	B	R	C	F	WB	E	FORK	STACK	REACH
XS	490	447	510	504	100	70,5	74,5	47	440	580	1010	71	382	510	371
S	510	467	520	514	120	71	74,5	47	440	587	1017	70	382	530	375
M	540	497	539	530	140	71,5	74	47	440	595	1025	70	382	551	380
L	560	517	560	549	160	72	73,5	47	440	606	1037	70	382	572	390
XL	590	547	580	570	180	72,5	73	47	440	617	1047	70	382	592	399

assembly

SORA MIX

Drivetrain	Shimano/Microshift 2x9
Handlebar	Cinelli 6061
Stem	Cinelli 6061
Seatpost	Cinelli 6061 Ø 31,6
Shifters	Shimano Sora 2x9
Brakes	Tektro MD-C510
Rotors	Tektro 160 mm
Ft. derailleur	Microshift R9 (FD-R352)
R. derailleur	Microshift R9 (RD-R43M)
Crankset	FSA Omega MegaExo 48-32t
Cassette	Sunrace 9 Speed / 11-34t
Chain	Kmc X9
Wheelset	Shining (A250) 32h Formula Hub front & rear
Tyres	Kenda Flintridge 700x35c
Saddle	Cinelli SSM Era

frame specs

Sizes	XS (49) - S (51) - M (54) - L (56) - XL (59)
Material	Columbus Zonal Triple Butted Alloy
Headset	IS 42/28,6 IS 47/33
Seatpost	Ø 31,6 mm
Seat Clamp	Ø 34,9 mm
BB Shell	BSA 68 mm
Ft. derailleur	Clamp Ø 34,9 mm
Routing	Internal
Color	Mr Blue Sky
Tyre Clear.	up to 700x40 mm
Fork	Columbus Futura Allroad 1-1/8" - 1-1/4" Carbon Monocoque
Weight	Frame 1760 g. (size M) Fork 450 g. (uncut)
Brake	Flat Mount, Rotor Size Up to 160 mm
Dropouts ST	Rear TA Ø 12x142mm - M12x165 / Front TA Ø 12x100mm - M12x119
Highlights	Front & Rear Fenders Ready / Rear Rack Eyelets / Fast Fuel Eyelets

zydeco electric mud

An ultralight, true gravel geometry,
E-bike for expanding the horizons
of your off-road riding.





zydeco electric mud

frame-kit - complete bike

- T800 Monocoque carbon frame and fork for 12,8kg complete bike weight
- 100km or 1000m ascent range for new adventures
- Internal hub motor allows for the E-Mud to maintain a 100% pure gravel geometry
- Dedicated app for all functions, custom configurations and detailed info
- Mahler Ebikemotion X35 engine

The Zydeco E-Mud is Cinelli's first e-bike, fruit of our experience developing the iconic King Zydeco. The E-Mud in fact maintains the same geometry and mould features of the King to guarantee a pure, unadulterated fast gravel feeling for the E-Mud. The use of an internal hub in fact allows for shorter chainstays than other Gravel e-bikes on the market and thus a faster, funner ride. Other features include 12,8kg complete bike weight, 100km or 1000m ascent range and a dedicated app for custom configurations and data.



specs

BIKE WEIGHT (M)

12,8 Kg

PRESS FIT

BB 86,5

MAX TYRE

**700x44
650bx48**

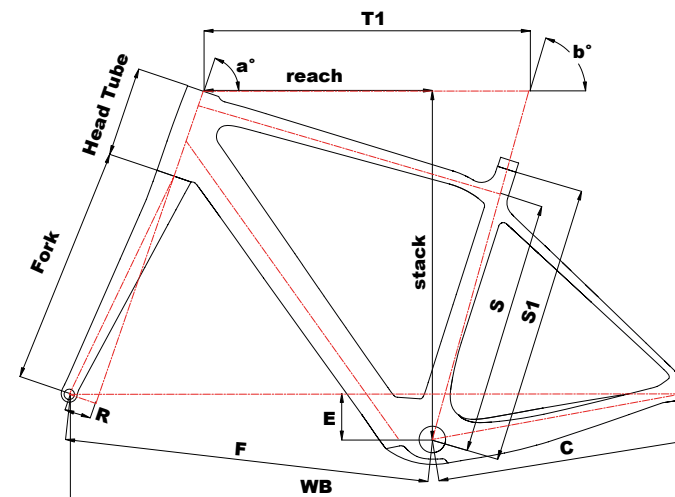

geometry

	S1	S	T1	H/T	A	B	R	C	F	WB	E	FORK	STACK	REACH
S	470	410	525	125	70,5	73	47	423	598	1009	75	402	556	373
M	500	440	549	150	71	72	47	423	611	1023	75	402	582	382
L	530	470	573	175	71,5	72	47	423	624	1041	75	402	608	392

assembly

MAHLER EBIKEMOTION X35 ENGINE + SHIMANO GRX MIX 1X11

Drivetrain	Shimano GRX Mix 1X11
Handlebar	Cinelli 6061
Stem	Cinelli 6061
Seatpost	Cinelli 6061 Ø 27,2
Shifters	Shimano GRX ST-RX400 1X11
Brakes	Shimano GRX 400 BR-RX400
Rotors	Shimano SM-RT70 160mm Center Lock
Ft. derailleur /	
R. derailleur	Shimano GRX RD-RX812
Crankset	FSA Gossamer 1X / 40T
Cassette	Shimano SLX CS-M8000 / 11-42 / 11s
Chain	Shimano CN-HG601
Wheelset	HY-NDR30AC
Tyres	Vittoria Terreno Dry 700x40C
Saddle	Selle Italia Model X

frame specs

Sizes	S (47) - M (50) - L (53)
Material	Columbus Carbon Monocoque
Headset	IS 42/28,6 IS 52/40
Seatpost	Ø 27,2 mm
Seat Clamp	Ø 31,8 mm Included
BB Shell	Press Fit 86,5x41
Ft. derailleur	Braze-on
Routing	Internal - Di2 compatible
Color	Fullcolor
Tyre Clear.	up to 700x44 / 650x48
Fork	Columbus Disc tapered 1-1/2" Carbon Monocoque
Weight	Frame 1420 g. (size M) Fork 450 g. (uncut)
Brake	Flat Mount, Rotor Size Up to 160 mm
Dropouts ST	Front TA Ø12x100mm / M12x1,5 L125mm skewer (incl.) Rear EBIKEMOTION axle std O.L.D. 136mm
Highlights	Di2 cable inserts / Front skewer / Rear carrier eyelets



ROAD GRAVEL ADVENTURE URBAN

zydeco electric mud fb

An ultralight, true gravel geometry,
E-bike for expanding the horizons of
your off-road riding.

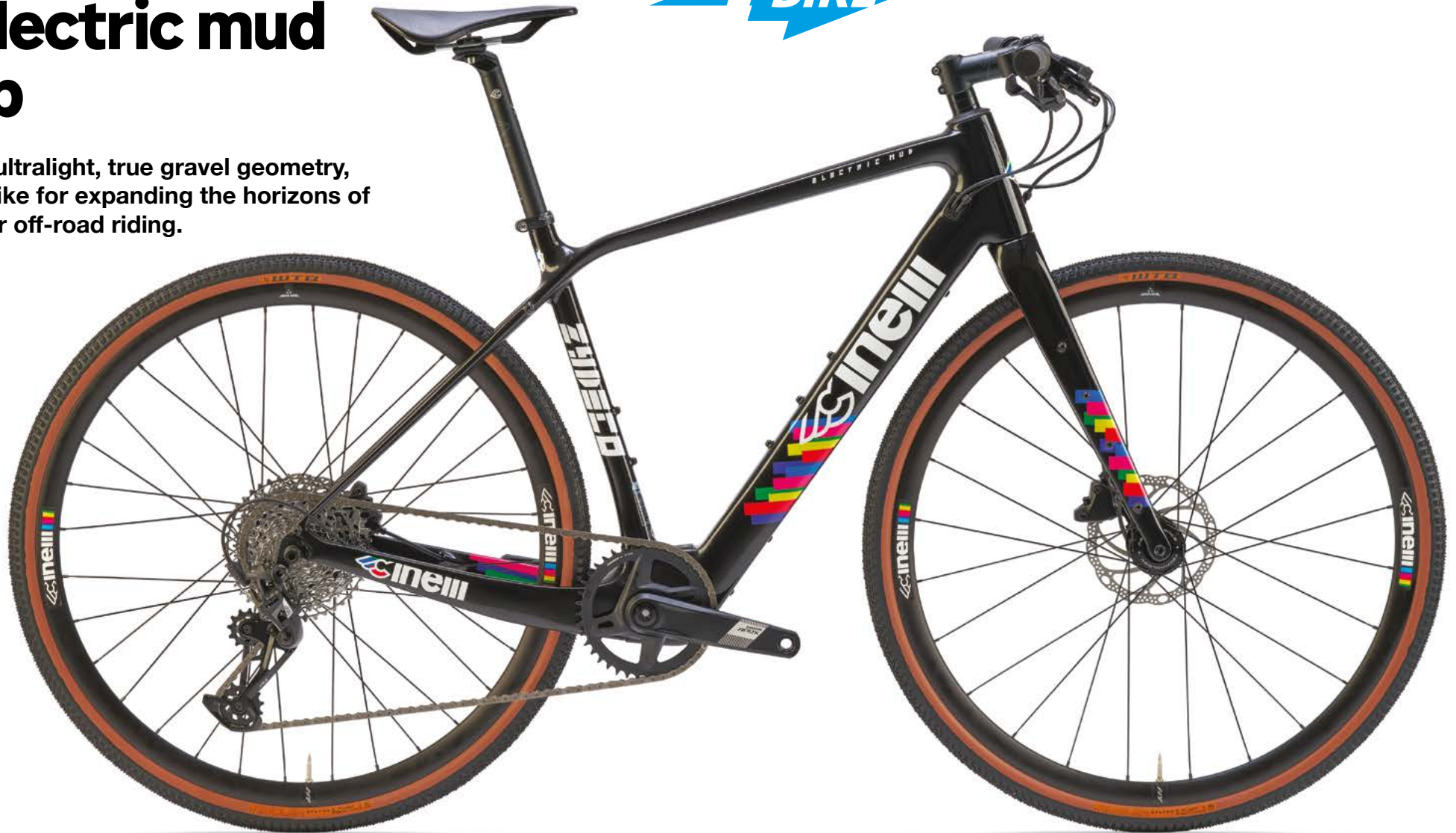

*The image has the sole purpose of presenting the product.
Some assembly specifications may vary.*





ROAD GRAVEL ADVENTURE URBAN

zydeco electric mud fb

complete bike

- T800 Monocoque carbon frame and fork for 12,8kg complete bike weight
- 720mm flat bar for maximum control and safety
- 100km or 1000m ascent range for new adventures
- Internal hub motor allows for the E-Mud to maintain a 100% pure gravel geometry
- Dedicated app for all functions, custom configurations and detailed info

The zydeco e-mud is cinelli's first e-bike, fruit of our experience developing the iconic king zydeco. The e-mud in fact maintains the same geometry and mould features of the king to guarantee a pure, unadulterated fast gravel feeling for the e-mud. The use of an internal hub allows for shorter chainstays than other gravel e-bikes on the market and thus a faster, funner ride. The choice of flat bars for this new build makes the bike even more fun and easy to ride, opening up its use to an entirely new range of users and uses.

Other features include 12,8kg complete bike weight, 100km or 1000m ascent range and a dedicated app for custom configurations and data.



specs

BIKE WEIGHT (M)	PRESS FIT	MAX TYRE
12,8 Kg	BB 86,5	700x44 650bx48

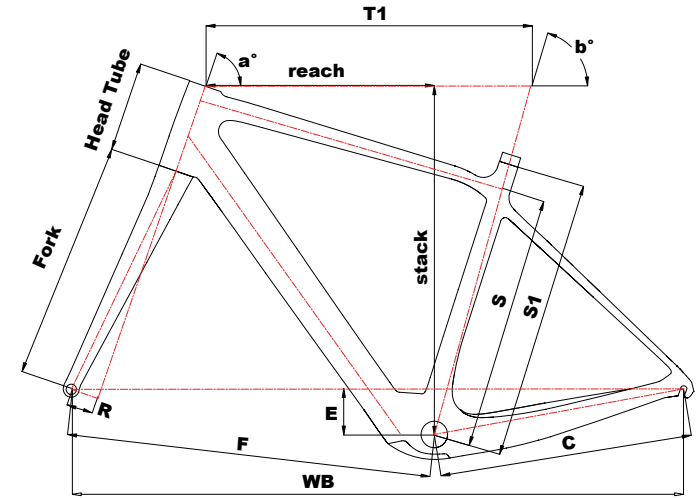

geometry

	S1	S	T1	H/T	A	B	R	C	F	WB	E	FORK	STACK	REACH
S	470	410	525	125	70,5	73	47	423	598	1009	75	402	556	373
M	500	440	549	150	71	72	47	423	611	1023	75	402	582	382
L	530	470	573	175	71,5	72	47	423	624	1041	75	402	608	392

assembly

MAHLER EBIKEMOTION X35 ENGINE + SRAM APEX XPLR 12sp

Drivetrain	Sram Apex XPLR 12sp
Handlebar	Cinelli Wand width 720mm
Stem	Cinelli Vai
Seatpost	Cinelli Vai
Shifters	Sram SX Eagle
Brakes	Tektro HD-285
Rotors	Tektro TR-160-22 diam.160mm
Ft. derailleur /	
R. derailleur	Sram Apex XPLR
Crankset	Sram Apex Wide 40t
Cassette	Sram PG-1231 XPLR 11-44t
Chain	Sram Apex
Wheelset	HY-NDR30AC
Tyres	Vittoria Terreno Dry 700x40 – WTB Riddler 700x37
Saddle	Selle Italia Model X

frame specs

Sizes	S (47) - M (50) - L (53)
Material	Columbus Carbon Monocoque
Headset	IS 42/28,6 IS 52/40
Seatpost	Ø 27,2 mm
Seat Clamp	Ø 31,8 mm Included
BB Shell	Press Fit 86,5x41
Ft. derailleur	Braze-on
Routing	Internal - Di2 compatible
Color	Fullcolor
Tyre Clear.	up to 700x44 / 650x48
Fork	Columbus Disc tapered 1-1/2" Carbon Monocoque
Weight	Frame 1420 g. (size M) Fork 450 g. (uncut)
Brake	Flat Mount, Rotor Size Up to 160 mm
Dropouts ST	Front TA Ø12x100mm / M12x1,5 L125mm skewer (incl.) Rear EBIKEMOTION axle std O.L.D. 136mm
Highlights	Di2 cable inserts / Front skewer / Rear carrier eyelets

nemo tig gravel

The ultimate designer gravel bike. Made in Milano, fine-tuned for the world's most extreme gravel adventures.





nemo tig gravel

frame-kit - complete bike

- **NEW:** Completely re-designed geometry for more extreme terrains
- **NEW:** 700 x 47mm tyre clearance thanks to our proprietary investment cast yoke
- **NEW:** Designed specifically for Hi-Ride Sterra fork system: 20mm of true hydraulic travel optimized for gravel riding combined with stiffest gravel suspension legs on the market, low maintenance and many other features.
- **NEW:** As of March 2023 all Nemo frames are manufactured within the Cinelli Milan HQ by our internal framebuilder allowing us to create the world's shortest supply chain for premium road bikes.
- **NEW:** custom-shaped seat stays with oriented ellipses and lowered seat tube welding pointing to optimize long-distance comfort
- **NEW:** Seat collar
- Custom drawn Columbus Spirit triple-butted tubes
- Adaptive geometry on rigid fork option thanks to Columbus fork dropouts that allow to change the rake from 47 to 52 mm
- Design-driven detailing and finish
- Available in 69 different paint and finish options



available also with rigid fork

specs

FRAME WEIGHT (M)	FORK WEIGHT (M)	BOTTOM BRACKET	MAX TYRE
2000 g	480 g	T47	47 mm

Radically overhauled for 2024, the Nemo Gravel represents our most intensely hybridized and extreme adventure gravel bike ever, entirely handcrafted by Cinelli's internal framebuilder in its Milanese HQ using custom drawn triple butted tube drawn by its sister company Columbus, less than 100 metres from the framebuilding workshop. Continuously refined over a one year period of testing by riders including former UCI World Champions, NYC courier legends, professional snowboarders and many other athletes pushing to redefine the limits of what gravel cycling can be, the Nemo Gravel is characterized above all by its completely redesigned geometry, 700 x 47mm tyre clearance and the use of the Hi-Ride Sterra fork with 20mm of true hydraulic travel. Together these features work to create a bike that is ready to tackle the world's most extreme gravel competitions and adventures.

**READY TO SHIP COLOUR:
BROWN, GLOSSY FINISH, WHITE DECALS.**

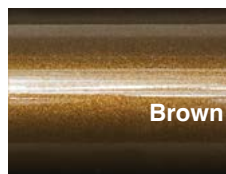

assembly

	EKAR	RIVAL axS XPLR	GRX 1x	GRX 2x
Drivetrain	Campagnolo Ekar	Sram Rival AXS XPLR	Shimano GRX	Shimano GRX
Handlebar	Cinelli Swamp	Cinelli Swamp	Cinelli Swamp	Cinelli Swamp
Stem	Alu 6061	Alu 6061	Alu 6061	Alu 6061
Seatpost	Cinelli Vai Ø 27,2	Cinelli Vai Ø 27,2	Cinelli Vai Ø 27,2	Cinelli Vai Ø 27,2
Shifters	Campagnolo Ekar	Sram Rival AXS	Shimano GRX	Shimano GRX
Brakes	Campagnolo Ekar	Sram Rival Hydro Disc	Shimano GRX	Shimano GRX
Rotors	Campagnolo Ekar	Paceline 160 mm	Shimano MT-800 160 mm	Shimano MT-800 160 mm
Ft. derailleur	/	/	/	/
R. derailleur	Campagnolo Ekar	Sram Rival AXS XPLR	Shimano GRX	Shimano GRX
Crankset	Campagnolo Ekar 40T	Sram Rival 1 Wide 40t	Shimano GRX 40t	Shimano GRX 48/31t
Cassette	Campagnolo Ekar 9-42T	Sram Rival XPLR 10/44t	Shimano GRX	Shimano GRX
Chain	Campagnolo Ekar	Sram Rival	Shimano	Shimano
Wheelset	Fulcrum Rapid Red 500 DB	Fulcrum Rapid Red 500 DB	Fulcrum Rapid Red 500 DB	Fulcrum Rapid Red 500 DB
Tyres	Vittoria Terreno Dry 700x47	Vittoria Terreno Dry 700x47	Vittoria Terreno Dry 700x47	Vittoria Terreno Dry 700x47
Saddle	SSM Shortfit	SSM Shortfit	SSM Shortfit	SSM Shortfit

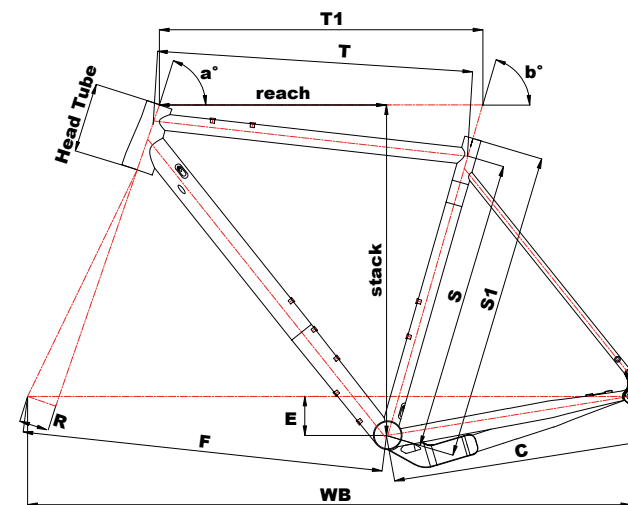

geometry

	S1	T1	H/T	A	B	R	C	F	WB	E	FORK	STACK	REACH
XS	480	530	110	70	74,5	47/52	430	616	1034	68	435	564	374
S	520	550	110	70	74,5	47/52	430	632	1053	68	435	564	393
M	540	565	120	71	74	47/52	430	633	1054	68	435	578	399
L	560	585	130	72	73,5	47/52	430	638	1059	68	435	591	410
XL	590	600	140	72,5	73	47/52	430	642	1063	68	435	603	416
XXL	610	615	160	72,5	73	47/52	430	658	1079	68	435	622	425

frame specs

Sizes	S (51) - M (54) - L (56) - XL (59) - XXL (61) / Made to Measure
Material	Columbus Spirit HSS Tubaset
Headset	IS 42/28,6 IS 52/40
Seatpost	Ø 27,2 mm
Seat Clamp	CNC Machine ø 29,8
BB Shell	T47 68 mm
Ft. derailleur	Clamp Ø 28,6mm
Routing	External / Internal Hydraulic Disc Brake Housing
Color	Brown (+3 Custom colors and +33 Colors matt or glossy)
Tyre Clear.	up to 700x47 mm
Fork	HiRide Sterra \ Fork Columbus Disc 1-1/8" - 1-1/2" Carbon Monoc.
Weight	Frame 2000 g. (size M) Columbus Fork 480 g. (uncut) / Sterra 1300g
Brake	Flat Mount Disc Brake, rotor size up to 160mm (rear) - 180mm (front)
Dropouts ST	Rear TA Ø 12x142mm - M12x173 / Front TA Ø 12x100mm - M12x119
Highlights	Frame / Fork / Ft. Derailleur Clamp / Ft. & Re. Skewers / Headset

hobotleg

Continuously fine-tuned over a million kilometres and ten years of riding, the Hobo is our original, indestructible, go-anywhere travelmate



hobootleg

complete bike

- The world's most reliable adventure bike
- Meticulously fine-tuned details for the most demanding adventures and adventurers
- Double-butted Columbus tubes
- Electrophoretic paint
- Tubus racks
- Ovalized handlebar sections
- Spare wheel spokes for on-the-road repairs
- Ready-to-ride anywhere and everywhere, right out of the box
- Steering limitation system (Ergo Steering Stop)
- External cable routing

There is no adventure like a hoboing adventure. Since its original conception for the mythical Tour d'Afrique of 2012, the Hobootleg has been continuously fine-tuned across more than a million kilometres, all of the world's seven highest mountain passes, the Guinness World Record-holding globe crossing and many other adventures to become the world's most reliable adventure bike. Thanks to obsessive details such as double-butted Columbus tubes, electrophoretic paint, Tubus racks, ovalized handlebar and spare wheel spokes the Hobootleg is ready to ride straight out of the box, anywhere, for as long as you like, any way you like...



specs

BIKE WEIGHT **14,2 Kg** BOTTOM BRACKET **BSA** MAX TYRE **42 mm**

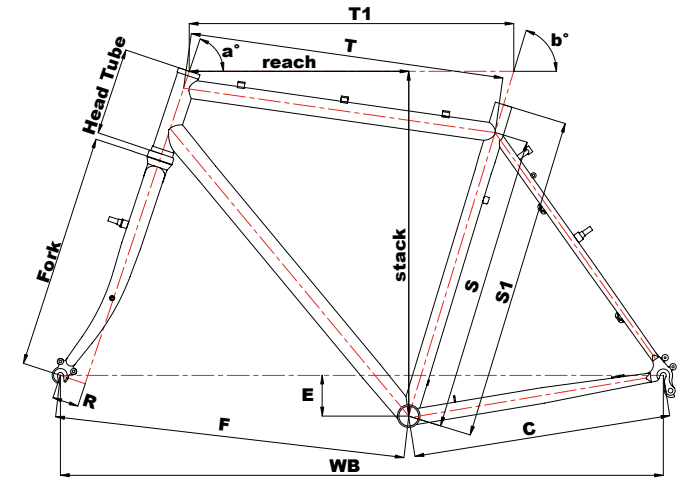

geometry

	S1	S	T1	T	H/T	A	B	R	C	F	WB	E	FORK	STACK	REACH
S	490	440	520	504	105	70	74	45	420	594	1025	70	410	549	362
M	530	480	540	523	125	71	73,5	45	420	600	1031	70	410	572	370
L	560	510	560	543	145	71,5	73	45	420	610	1041	70	410	593	379
XL	590	540	580	563	165	71,5	72,5	45	420	625	1055	70	410	612	387
XXL	610	560	600	579	185	72	72	45	420	634	1064	70	410	643	391

assembly

MICROSHIFT

Drivetrain	Microshift
Handlebar	Cinelli Bootleg
Stem	Cinelli Bootleg
Seatpost	Cinelli 6061
Shifters	Right & Left Microshift (BS-T09) Bar End Shifter / 9 Speed Micro Index Right - 2/3 Speed Index Friction Left
Brakes	Front & Rear Tektro (992AG) / Road Racing Lever Tektro (RL340)
Rotors	/
Ft. derailleur	Microshift (FD-R 353SB)
R. derailleur	Microshift (RD-M46L) - 9 Speed
Crankset	Prowheel Zephyr-701 / 48-36-26t
Cassette	Microshift - 9 Speed - 11-34t
Chain	Kmc (Z9)
Wheelsset	Front & Rear WTB ST i19 TCS 2.0 - 36h - Shimano Hub (HB-RS300) - Tubeless compatible
Tyres	WTB Riddler 700x37c Tan Sidewall
Saddle	WTB Volt

frame specs

Sizes	S (49) - M (53) - L (56) - XL (59) - XXL (61)
Material	Columbus Cromor Double Butted Steel
Headset	EC 34/28,6 EC 34/30
Seatpost	Ø 27,2 mm
Seat Clamp	Ø 29,8 mm
BB Shell	BSA 68 mm
Ft. derailleur	Clamp Ø 28,6 mm
Routing	External, Full Length Housing
Color	Red Right Hand
Tyre Clear.	Up to 700x38 mm With Fenders - Up to 700x40 mm Without Fenders
Fork	Columbus Cr-Mo Steel 1-1/8"
Weight	Frame 2300 g. (size M) - Fork 1250 g. (uncut)
Brake	Cantilever
Dropouts ST	Rear QR 130 mm - Front QR 100mm
Highlights	EDP / Ergo Steering Stop / Bar End Shifters / Ft & Re, Tubus Rack

hobotleg geo

Our most advanced adventure bike ever, takes the signature characteristics of our indestructible Hobo and tunes them for technical and single-track journeys.





hobootleg geo

complete bike

- Hardtail MTB-derived geometry
- Flared handlebars
- 6-eyelet “go-anywhere” Columbus Futura Adventure fork
- Adaptive geometry thanks to Columbus fork dropouts that allow to change the rake from 47 to 52 mm
- Columbus Cromor double-buttressed steel tubing
- Max tyre clearance 29x3,0”/ 27,5x3,0”
- All specs fine-tuned over a period of three years of testing



The Hobootleg Geo is Cinelli’s most advanced adventure bike ever. It has been designed to take the signature characteristics of our indestructible self-sufficient world-traveller, the original Hobo model, and tweak it for single-track, in particular technical mountain riding. Key features include flared handlebars, 6-eyelet fork, hydraulic disc brake caliper coupled with a mechanical actuator as well as a geometry that is derived from classic rigid mountainbikes. All details have been fine-tuned over a three-year testing period with our adventure ambassadors so that the bike is ready to tackle your most extreme rides straight out of the box without further modification.



specs

BIKE WEIGHT (M)	BOTTOM BRACKET	MAX TYRE
12,2 Kg	BSA	29x3,0" 27,5x3,0"

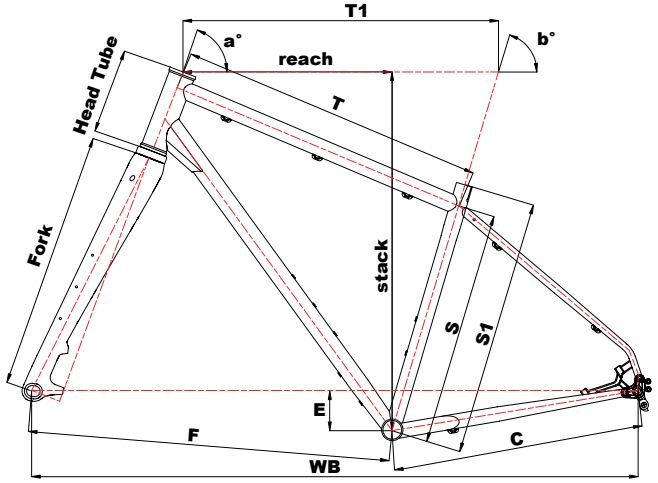

geometry

	S1	S	T1	T	H/T	A	B	R	C	F	WB	E	FORK	STACK	REACH
S	400	360	540	533	133	68	74	45/50	450	642	1083	70	468	620	362
M	460	420	570	552	153	69	73,5	45/50	450	657	1098	70	468	644	379
L	510	470	600	576	173	69	73	45/50	450	682	1123	70	468	663	397
XL	550	510	620	593	193	69	72,5	45/50	450	697	1138	70	468	682	405

assembly

SHIMANO TIAGRA 2x10 Mix

Drivetrain	Shimano Tiagra 2x10 mix
Handlebar	Cinelli Largo
Stem	Cinelli 6061
Seatpost	Cinelli 6061
Shifters	Shimano Tiagra ST-4700
Brakes	Tektro HD-C705C
Rotors	Tektro 160 mm
Ft. derailleur	Microshift FD-FD-M612-B
R. derailleur	Shimano GRX RD-RX400 / 10 Speed
Crankset	Prowheel (MPL-501-TT) / 36/26T
Cassette	Shimano CS-HG500-10 / 10 Speed / 11-34T
Chain	Kmc X10
Wheelsset	Front & Rear WTb ST 125 TCS 2.0 - 36h - Hubs Shimano (TC-500) Center Lock
Tyres	WTB Ranger / 29X2,25 / Tan Sidewall
Saddle	WTB Volt

frame specs

Sizes	S (40) - M (46) - L (51) - XL (55)
Material	Columbus Cromor Double Butted Steel
Headset	ZS 44/28,6 EC 44/30
Seatpost	Ø 27,2 mm
Seat Clamp	Ø 29,8 mm
BB Shell	BSA 73 mm
Ft. derailleur	Clamp on Ø 28,6 mm
Routing	External, Full Length Housing
Color	Sunrise
Tyre Clear.	Up to 29x3.0 / 27,5x3.0
Fork	Columbus Carbon Futura Adventure
Weight	Frame 2500 g. (size M) Fork 550 g. (uncut)
Brake	Post Mount Disc Brake, Rotor Size Up To 180 mm
Dropouts ST	Rear TA Ø 12x148mm - M12x170 / Front TA Ø 15x110mm - M15x150
Highlights	Rear Rack Eyelets / Anything Cage Eyelets / Dynamo Housing

hobootleg easy travel

A fast adventure bike for those who prefer STI levers and disc brakes





hobootleg easy travel

complete bike

- Fast adventure geometry
- STI levers and bar disc brakes
- 44mm max tyre clearance
- Double-buttressed Columbus tubes
- Electrophoretic paint

The Easy Travel is a fast adventure bike for those who prefer STI levers to bar ends, disc brakes and less complicated road surfaces. The bike, of course, shares its signature characteristics such as double-buttressed Columbus tubes and electrophoretic paint with its older-cousin, the indestructible self-sufficient world-travelling Hobootleg.



specs

BIKE WEIGHT **12,6 Kg** BOTTOM BRACKET **BSA** MAX TYRE **44 mm**

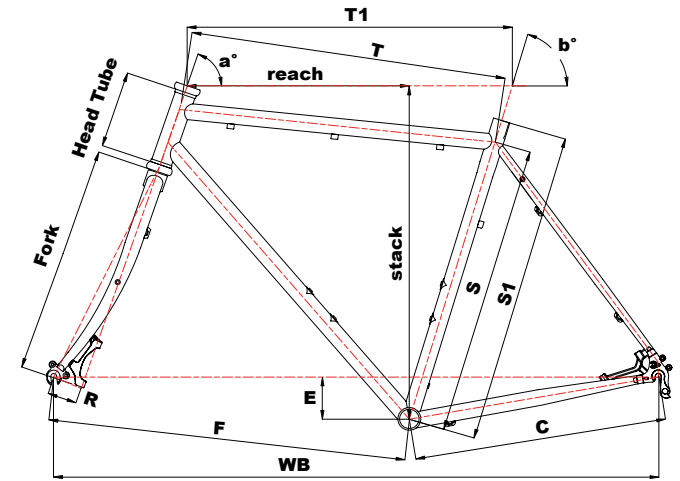

geometry

	S1	S	T1	T	H/T	A	B	R	C	F	WB	E	FORK	STACK	REACH
XS	480	440	520	507	80	70	73	55	440	590	1018	75	400	531	360
S	520	480	545	531	110	71	73	55	440	604	1033	75	400	563	373
M	550	510	564	552	135	71	73	55	440	624	1053	75	400	587	385
L	580	540	591	577	160	71,5	72,5	55	440	640	1069	75	400	612	398
XL	600	560	611	596	185	72	72,5	55	440	657	1086	75	400	638	410

assembly

SORA 3x9 MIX

Drivetrain	Sora 3x9
Handlebar	Cinelli 6061
Stem	Cinelli 6061
Seatpost	Cinelli 6061
Shifters	Shimano Sora
Brakes	Tektro MD-C605C
Rotors	Tektro TR160 160mm
Ft. derailleur	Microshift (FD-R353 SB) / 3 Speed / Band-Type
R. derailleur	Microshift (RD-M46 L) / 9 Speed
Crankset	FSA Tempo (Ck201TTT) / 50/39/30T
Cassette	Shimano (CS-HG400-9) / 9 Speed / 11-34T
Chain	KMC (Z9)
Wheelset	Front & Rear WTb ST i19 TCS 2.0 - 36h / Formula HUB (RX-25/26) Tubless compatible
Tyres	Kenda 700X35c
Saddle	WTB Volt

frame specs

Sizes	XS (48) - S (52) - M (55) - L (58) - XL (60)
Material	Columbus Cromor Double Butted Steel
Headset	EC 34/28,6 EC 34/30
Seatpost	Ø 27,2 mm
Seat Clamp	Clamp Ø29,8 mm
BB Shell	BSA 68 mm
Ft. derailleur	Clamp on Ø28,6 mm
Routing	External
Color	Yellow Line
Tyre Clear.	Up to 700x40 With Fenders - Up to 700x44 Without Fenders
Fork	Columbus Cr-Mo Steel 1"-1/8
Weight	Frame 2150 g. (size M) Fork 1050 g. (uncut)
Brake	Disc, Post Mount
Dropouts ST	Front QR 100mm - Rear QR 135mm
Highlights	Front Rack Middle Fork - Rear Rack Eyelet / Fender Eyelet

hobootleg interrail

Fast travel geometry, multi position flat-bar and other carefully-tuned features for our most versatile adventure bike.



T. V.



hobootleg interrail

- Fast adventure geometry
- “Double trouble” multi-position flat-bar for more upright position, long distance comfort and extra bag-mounting capacity
- Full mudguards
- Hydraulic disc brakes
- Iconic Cinelli “Hobo” design language
- Suited to year-round commuting as well as medium-difficult touring



Fast adventure geometry
 “Double trouble” multi-position flat-bar for more upright position, long distance comfort and extra bag-mounting capacity
 Full mudguards
 Disc brakes
 Iconic Cinelli “Hobo” design language
 Suited to year-round commuting as well as medium-difficult touring

specs

BIKE WEIGHT **12,2 Kg** BOTTOM BRACKET **BSA** MAX TYRE **42 mm**

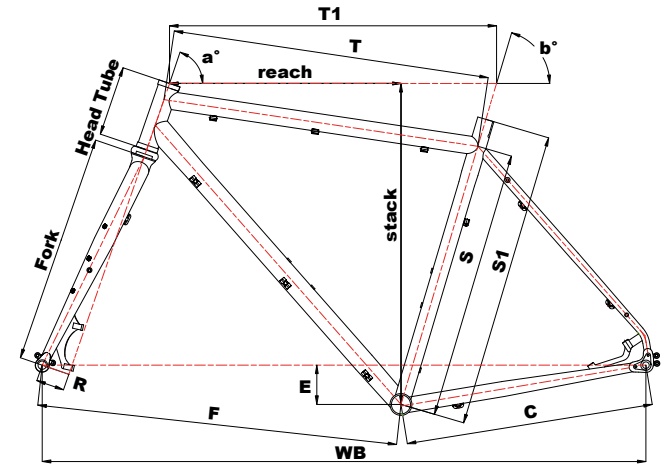

geometry

	S1	S	T1	T	H/T	A	B	R	C	F	WB	E	FORK	STACK	REACH
S	510	460	528	513	105	70	74	50	445	602	1037	70	410	549	370
M	545	495	559	542	135	71	73	50	445	614	1050	70	410	581	382
L	570	520	583	564	160	71,5	72,5	50	445	628	1064	70	410	607	392
XL	600	550	610	589	185	72	72	50	445	644	1079	70	410	633	404

assembly

SHIMANO DEORE 2X10

Drivetrain	Shimano Deore 2x
Handlebar	Cinelli Double Trouble
Stem	Cinelli 6061
Seatpost	Cinelli 6061
Shifters	Shimano Deore (SL-T6000)
Brakes	Front Tektro (HD-M285-F) / Rear Tektro (HD-M285-R)
Rotors	Tektro 160mm
Ft. derailleur	Shimano Deore FD-T6000-H3
R. derailleur	Shimano Deore (RD-T6000) / 10 Speed
Crankset	FSA Omega Mega Exo / 48/32T
Cassette	Shimano (CS-HG50-10) / 10 Speed / 11-36T
Chain	KMC (X10)
Wheelset	Shining A250 / 700C / 32H / 6 Bolt Disc / Formula Hub Ft. (DC-71) Re. (DHT-142)
Tyres	WTB Byway/ 700X34c Tan Sidewall
Saddle	WTB Volt

frame specs

Sizes	S (51) - M (54.5) - L (57) - XL (60)
Material	Columbus Cromor Double Butted Steel
Headset	EC 34/28,6 IC 34/30
Seatpost	Ø 27,2 mm
Seat Clamp	Ø 29,8 mm
BB Shell	BSA 68 mm
Ft. derailleur	Clamp Ø 28,6 mm
Routing	External Full Length Housing
Color	Emerald Pathway
Tyre Clear.	up to 700x42 mm with Fenders
Fork	Columbus Cr-Mo Steel 1-1/8"
Weight	Frame 2500 g. (size M) Fork 1500 g. (uncut)
Brake	Post Mount Disc Brake, rotor size up to 180 mm
Dropouts ST	Rear TA Ø 12x142mm - M12x165 / Front TA Ø 12x100mm - M15x125
Highlights	Ft. & Re. Fender And Rack Eyelets / Anything Cage Eyelets / Front Light Hole

tutto mini silver bootleg

A street-ready hybrid bike that combines elements from BMX, track bikes and gravel to create a uniquely fast and fun ride across city and countryside.



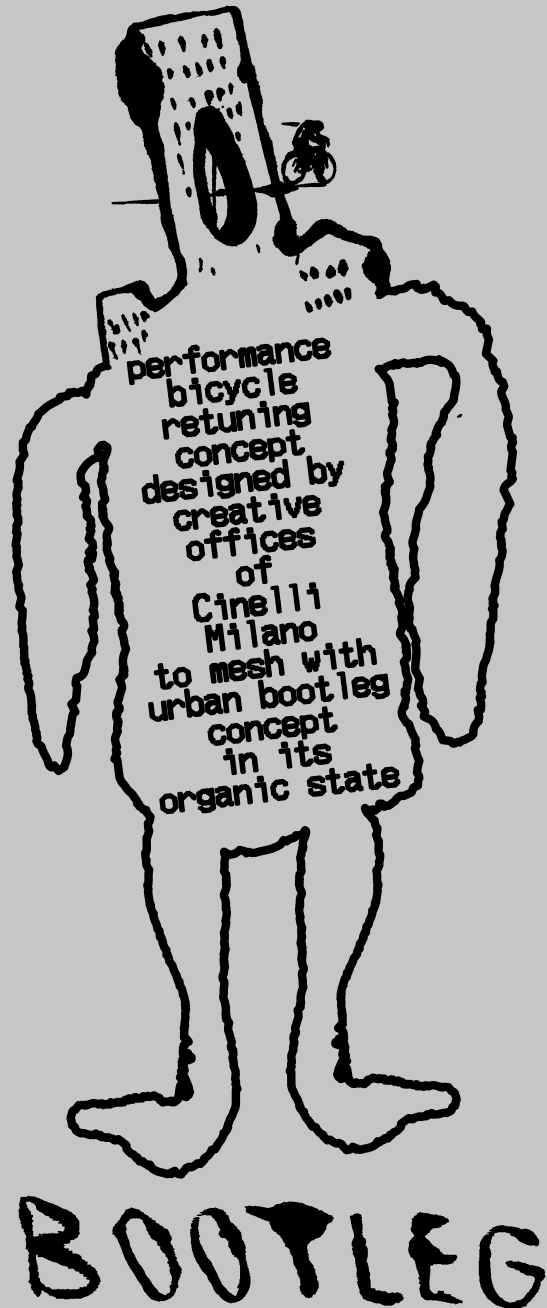

silver bootleg concept

This year sees the reintroduction of Cinelli's urban bootleg concept. Bootleg is conceived of as a treatment applied to what was originally a performance bicycle, retuning its visual appearance as well as technical characteristics for new attempts at escaping the mental and physical limits of the city i.e. **NEW STYLES OF URBAN CYCLING**. All "Silver Bootleg" colour bikes are characterized by heavy-duty silver paint that mimics the aesthetic of raw aluminium, tone-on-tone raised branding (as though the bike had been stolen and repainted) and reflective details.

For MY2024 the Bootleg treatment has been applied to two famous existing Cinelli models, the Zydeco and the Tutto Plus, as well as entirely new platform, the Tutto Mini.

tutto mini silver bootleg

frame-kit - complete bike

- Adjustable disc brake slider dropouts for both fixed gear, single speed and geared setups
- Total 19 eyelets for maximum versatility and cargo-carrying possibilities
- 25c wheels for the best compromise between speed and technical terrain handling, with max clearance for MTB tyres
- BMX-style single speed setup 180mm rise handlebars and 50mm stem
- Belt-drive compatible
- Quick-release seatpost for fast disassembly, increasing transport options
- Vintage American MTB-style segmented fork crown
- Silver Bootleg graphic concept including reflective details and 3D decals



specs

FRAME WEIGHT (M)	FORK WEIGHT (M)	bottom bracket	MAX TYRE
2000 g	1850 g	BSA	20x2,5"

The Tutto Mini is an ultra-hybridized homage to our roots and culture, from BMX to track bikes to gravel. Built on 25c wheels for the best compromise between easy packability, fast accelerations and true technical handling, the Tutto Mini can do anything you want it do: from slick fixed-gear riding to gravel touring to tricks and everyday urban commuting. The Tutto Mini frame is in fact a highly detailed, highly versatile piece of equipment that takes its design cues from our pioneering tracklocross bike, the Tutto Plus and features adjustable disc brake slider dropouts, a total of 19 eyelets, a vintage MTB-style segmented fork crown, reflective details, 3D decals and much, much, more.

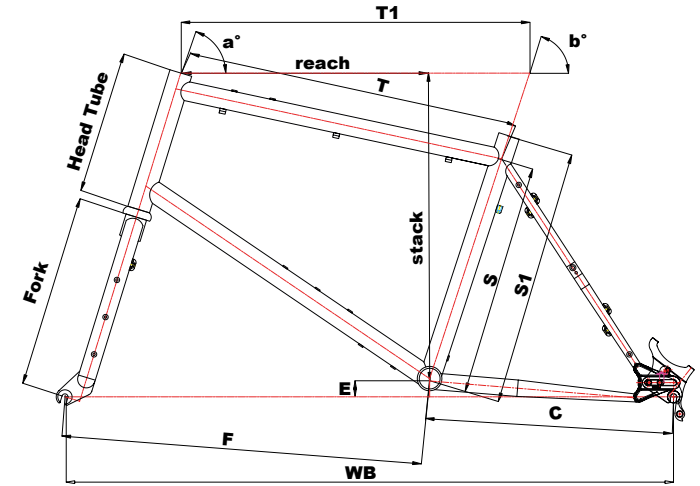

geometry

	S1	S	T1	T	H/T	A	B	R	C	F	WB	E	FORK	STACK	REACH
S	360	320	520	495	185	73	72	25	400	547	945	30	317	455	372
L	420	380	570	544	235	73	72	25	400	596	994	30	317	503	407

assembly

SINGLE SPEED

Drivetrain	/
Handlebar	HL Ø 22,2 - 180 mm Rise / Width 620 mm
Stem	HL Ø 22,2 - Length 50 mm
Seatpost	Cinelli Alloy Ø 31,6 - L 450 mm
Shifters	/
Brakes	Tektro (RS-360A) Lever - Ø 22,2 / Tektro (MD-C605C) Front & Rear
Rotors	Tektro TR 160 mm
Ft. derailleur	/
R. derailleur	/
Crankset	Prowheel Solid 48t / 170 mm
Cassette	Singlespeed 16t
Chain	KMC (410 HA)
Wheelset	Alloy 406x25c - Alloy 6 bolt
Tyres	Kenda K-Rad 20x2.125
Saddle	PVC Saddle Black

frame specs

Sizes	S (36) - L (42)
Material	Steel
Headset	EC 34/28,6 EC 34/30
Seatpost	Ø 31,6 mm
Seat Clamp	Ø 34,9 mm
BB Shell	BSA 68 mm
Ft. derailleur	Clamp Ø 34,9 mm (not included)
Routing	Full External
Color	Silver Bootleg
Tyre Clear.	up to 20x2.5
Fork	Columbus Steel 1-1/8"
Weight	Frame 2000 g. (size M) Fork 1850 g. (uncut)
Brake	Front & Rear Disc PM 160
Dropouts ST	Front QR 100 mm / Rear QR 135 mm
Highlights	Sliding Dropouts, Adventure Eyelets

zydeco silver bootleg

Cinelli's gravel icon goes underground: our best-selling Zydeco is transformed into the ultimate flat-bar and front rack go-everywhere city bike.





zydeco silver bootleg

complete bike

- Heavy duty front rack (max load 8kg)
- Super wide 20mm riser handlebars
- High quality oversized triple-butted aluminium tubing
- Custom rivet system allows user endless further bag and rag options
- Max tyre clearance 700x40c
- Silver Bootleg graphic concept including reflectivedetails and 3D decals

Straight out of the global headquarters of the new Cinelli Bootleg design department comes this: Cinelli's beloved gravel icon, the Zydeco, transformed into the ultimate flat-bar & front-rack go everywhere city bike. Designed to withstand the demands of the most intense urban commuting, the Zydeco Silver bootleg is equipped with a heavy duty aluminium front rack (max load 8kg), firmly anchored to a customized version of Columbus' X carbon fiber fork, super wide 20 mm riser handlebars, 700 x 35c tyres (max tyre clearance 40c), custom rivet system, reflective details, 3D decals and much, much, more.



specs

BIKE WEIGHT **10,3 Kg** BOTTOM BRACKET **BSA** MAX TYRE **40 mm**

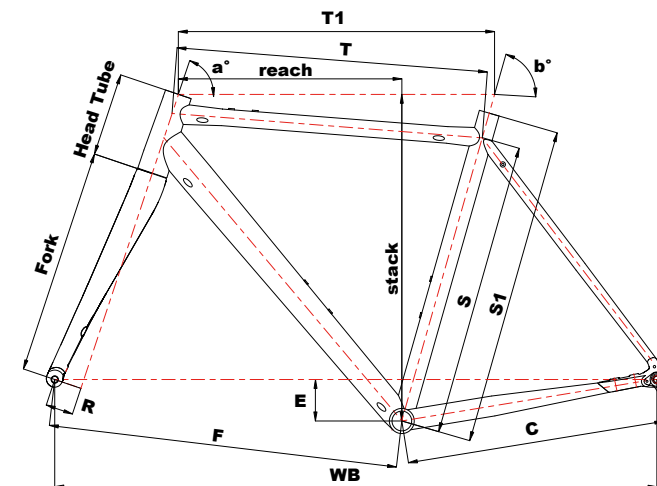

geometry

	S1	S	T1	T	H/T	A	B	R	C	F	WB	E	FORK	STACK	REACH
XS	490	447	510	504	100	70,5	74,5	47	440	580	1010	71	382	510	371
S	510	467	520	514	120	71	74,5	47	440	587	1017	70	382	530	375
M	540	497	539	530	140	71,5	74	47	440	595	1025	70	382	551	380
L	560	517	560	549	160	72	73,5	47	440	606	1037	70	382	572	390
XL	590	547	580	570	180	72,5	73	47	440	617	1047	70	382	592	399

assembly

MICROSHIFT 1X10

Handlebar	Riser Al 6061 / Ø 31,8 / Rise 20mm / Backsweep 6° / Width 680 mm
Stem	Cinelli 6061 Ø 31,8 Angle 6° H 40 mm / XS 90 - S 90 - M 100 - L 110 - XL 110
Seatpost	Cinelli 6061 Ø 31,6 L 350
Shifters	Microshift SL-M9605-R 10 Speed
Brakes	Tektro MD-C510 + Tektro Levers RX-1.0
Rotors	Tektro TR160 160mm
R. derailleur	Microshift RD-M6205AM
Crankset	FSA Omega MegaExo 40t / XS 170 - S 170 - M 172,5 - L 172,5 - XL 175
B. Bracket	FSA BSA68
Cassette	Microshift CS-H104 / 10 Speed / 11-48t
Chain	Kmc X10
Wheelset	Shining (A250) 32h Formula Hub front & rear
Tyres	Kenda 700x35c
Saddle	Cinelli SSM Rnd
Tape	Rubber grip
Rack	O-Stand CD-810 (Included)

frame specs

Sizes	XS (49) - S (51) - M (54) - L (56) - XL (59)
Material	Triple Butted Alloy
Headset	IS 42/28,6 IS 47/33
Seatpost	Ø 31,6 mm
Seat Clamp	Ø 34,9 mm
BB Shell	BSA 68 mm
Ft. derailleur	Clamp Ø 34,9 mm
Routing	Internal
Color	Silver Bootleg
Tyre Clear.	up to 700x40 mm
Fork	Columbus Alu-Carbon1-1/8" - 1-1/4"
Weight	Frame 1760 g. (size M) Fork 600 g. (uncut)
Brake	Flat Mount, Rotor Size Up to 160 mm
Dropouts ST	Rear TA Ø 12x142mm - M12x165 / Front TA Ø 12x100mm - M12x119
Highlights	Front & Rear Fenders Ready / Front & Rear Rack Eyelets / Fast Fuel Eyelets

tutto plus silver bootleg

The original “tracklocross”
bike and the world’s most
hybridized single-speed





tutto plus silver bootleg

complete bike

- **NEW** Silver Bootleg graphic concept including reflective details and 3D decals
- The original multi-purpose multi-surface track frame
- Track dropouts with rear derailleur braze-ons for geared options
- 45mm fork rake
- Full mudguard eyelets
- Vintage MTB-style segmented fork crown
- Tyre clearance up to 45mm

Tutto Plus is the original do-everything high-performance urban- track frame, in constant evolution since first being launched 8 years ago. The bike can quickly morph from messenger work bike complete with front rack, to alleycat race bike to single-speed cross machine, to indestructible commuter. Made with butted steel tubes, the Tutto has been designed to be able to mount a rear derailleur and a modern road race wheel. A vintage MTB-style segmented TIG welded fork improves rigidity as well as the overall aggressive street-ready aesthetic of the bike and is complemented by the new Silver Bootleg graphic concept including reflective details and 3D decals.



specs

BIKE WEIGHT (M)
10,2 Kg

FORK RAKE
45 mm

BOTTOM BRACKET
BSA

MAX TYRE
45 mm

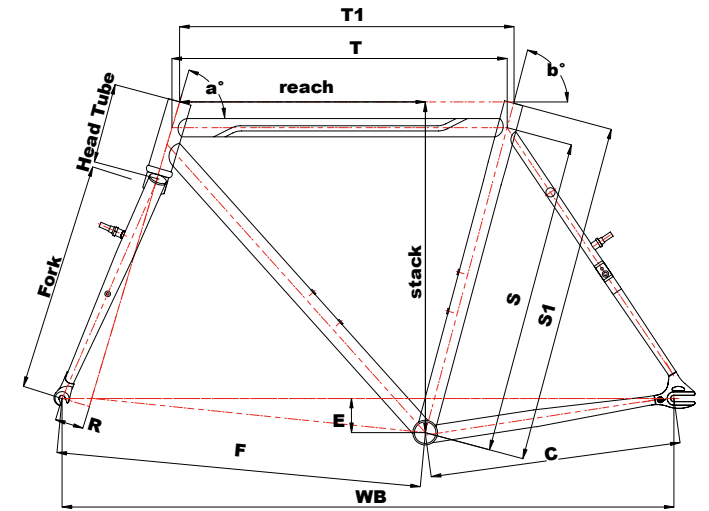

geometry

	S1	S	T1	T	H/T	A	B	R	C	F	WB	E	FORK	STACK	REACH
S	520	480	510	506	90	71,5	75,5	45	425	579	987	60	392	515	378
M	540	500	540	537	100	72,5	75,5	45	425	595	1003	60	392	528	398
L	560	520	560	560	110	72	74,5	45	425	616	1024	60	392	536	410
XL	590	550	585	585	130	73,5	74	45	425	622	1030	60	392	560	424

assembly

SINGLE SPEED

Drivetrain	/
Handlebar	Cinelli Flat Handlebar Ø 31,8 - 15 mm Rise / S 680 - M 680 - L 680 - XL 680
Stem	Cinelli 6061 Ø 31,8 - Angle 6° - H 40 mm / S 90 - M 90 - L 100 - XL 100
Seatpost	Cinelli 6061 Ø 27,2 - L 350 mm
Shifters	/
Brakes	Tektro (CL-330TS) Lever - Ø 22,2 / Tektro (C-310) V-Brake Front & Rear
Rotors	/
Ft. derailleur	/
R. derailleur	/
Crankset	Lasco CNC 46t / S 170 - M 170 - L 170 - XL 170
Cassette	Shining Singlespeed 18t
Chain	KMC (Z1)
Wheelset	Shining (A-M3) 700C - 32H - KT Hub (DSPF) front / Shining (A-M3) 700C - 32H - KT Hub (5VAR) rear
Tyres	Kenda Kwick-Trax 700x35c
Saddle	DDK Black

frame specs

Sizes	S (52) - M (54) - L (56) - XL (59)
Material	Steel
Headset	EC 34/28,6 EC 34/30
Seatpost	Ø 27,2 mm
Seat Clamp	Ø 29,8
BB Shell	BSA 68 mm
Ft. derailleur	Clamp Ø 28,6 mm (not included)
Routing	Full External
Color	Silver Bootleg
Tyre Clear.	up to 700x45 mm
Fork	Columbus Steel 1-1/8"
Weight	Frame 2100 g. (size M) Fork 1150 g. (uncut)
Brake	Front & Rear Removable V-Brake Pivot Studs
Dropouts ST	Front QR 100 mm / Rear QR 130 mm
Highlights	Ft. Light Hole / Ft. & Re. Fender, Derailleur Compatibility & Rack Eyelets

vigorelli

The world's most famous track bike, born on the velodrome in Milan but a global cult for weaving through traffic...



TV!



vigorelli

frame-kit

- Pure track reactive geometry (377mm chain stays in all sizes)
- Negative sloping top tube
- Aerodynamic blade seat tube
- Columbus Futura carbon monocoque carbon fork (1-1/8" – 1-1/2")
- UCI-approved for track competition



Since first launching in 2005 the Cinelli Vigorelli has become the world's most famous track bike, intimately associated with wave after wave of reappropriation of fixed gear bikes by urban racing subcultures. The frame itself has undergone continuous performance tweaks, fruit of collaboration with our extended family of different athletes, from pure track frame, to fixed gear crit specialist, to traffic-weaving machine... For 2023 the frame returns to its track performance roots, tuned for velodrome specialists (without forgetting urban riders looking for the ultimate speed thrill...).

specs

FRAME WEIGHT (M)	FORK WEIGHT (M)	BOTTOM BRACKET	MAX TYRE	FORK RAKE
1550 g	350 g	BSA	28 mm	45 mm

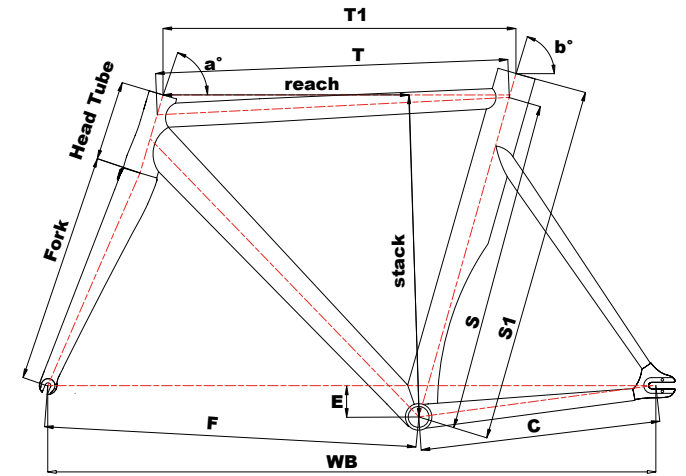

geometry

	S1	S	T1	T	H/T	A	B	R	C	F	WB	E	FORK	STACK	REACH
XS	520	480	500	507	95	73	73,5	45	377	543	914	50	368	478	359
S	550	510	526	535	115	73	74	45	377	572	944	50	368	497	384
M	570	530	558	567	130	73,5	74	45	377	597	968	50	368	514	410
L	590	550	587	598	145	74	74	45	377	622	993	50	368	530	435
XL	605	565	621	632	160	74	73,5	45	377	651	1022	50	368	545	460

frame specs

Sizes	XS (52) - S (55) - M (57) - L (59) - XL (60,5)
Material	Columbus Airplane Triple Butted Alloy
Headset	IS 42/28,6 IS 52/40
Seatpost	Dedicated Aero Alu Seatpost L350
Seat Clamp	Dedicated Aero Seat Clamp
BB Shell	BSA 68 mm
Ft. derailleur	/
Routing	Rear Brake Internal Routing
Color	Rainbow - Special White
Tyre Clear.	up to 700x28 c
Fork	Columbus Futura Caliper 1-1/8" - 1-1/2" Carbon Monoc.
Weight	Frame 1550 g. (size M) Fork 350 g. (uncut) Seatpost 200 g.
Brake	Standard Rim Brake
Dropouts ST	Front QR 100mm - Rear QR 120mm / Stainless Steel Removable Plates
Highlights	Seatpost / Seatclamp / Headset - Expander

gazzetta della strada

A flat-bar and front-rack hybridization of the classic Randonnée bike, perfect for fast commuting and summer adventures.





← M9C/1

39

HUMEN

TRISTE
ti d'energia
Hano vel mio re
Kraista qaro
ti fine
quo g
D-holl

gazzetta della strada

complete bike

- Columbus Cromor double-buttressed steel tubing
- Mechanical disc brakes
- Front messenger rack
- 700 x 35mm tyres
- Metallic paint and vintage branding

The Gazzetta della Strada is Cinelli's hybridized vision of the classic steel Randonée bike, fine-tuned – thanks to its flat bars, messenger rack and road-inspired geometry - for riders for whom fast and practical commuting is the ultimate priority without neglecting the versatile design details that make the bike weekend-adventure ready.



specs

BIKE WEIGHT
12,5 Kg

FORK RAKE
55 mm

MAX TYRE
44 mm

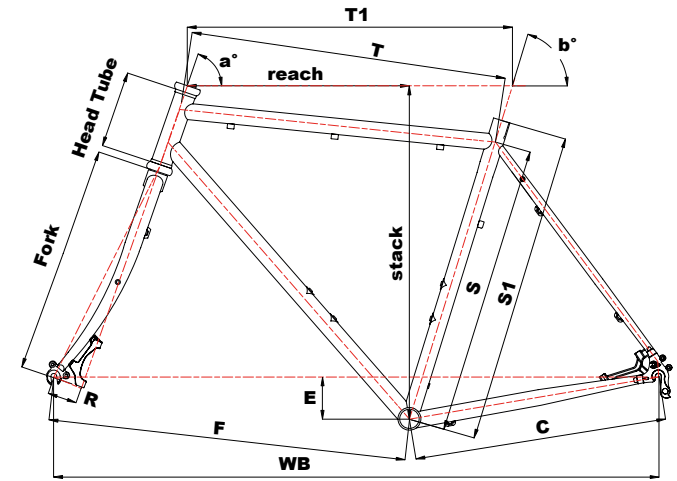

geometry

	S1	S	T1	T	H/T	A	B	R	C	F	WB	E	FORK	STACK	REACH
XS	480	440	520	507	80	70	73	55	440	590	1018	75	400	531	360
S	520	480	545	531	110	71	73	55	440	604	1033	75	400	563	373
M	550	510	564	552	135	71	73	55	440	624	1053	75	400	587	385
L	580	540	591	577	160	71,5	72,5	55	440	640	1069	75	400	612	398
XL	600	560	611	596	185	72	72,5	55	440	657	1086	75	400	638	410

assembly

MICROSHIFT 9v

Handlebar	Cinelli Flat Handlebar Ø 31,8 / 560 mm
Stem	Cinelli 6061 Ø 31,8 / XS 100 - S 100 - M 100 - L 110 - XL 110
Seatpost	Cinelli 6061 Ø 27,2 L 350
Shifters	Microshift SL-M859 / 2x9 Speed
Brakes	Tektro MD-M280
Rotors	Tektro TR160 160mm
Ft. derailleur	Microshift (FD-T392-B)
R. derailleur	Microshift (RD-M46L) / 9 Speed
Crankset	FSA Vero Compact / 46-36T / XS 170 - S 170 - M 170 - L 175 - XL 175
B. Bracket	FSA (BB-7420ST) / BSA 68mm
Cassette	Shimano (CS-HG400) / 9 Speed / 11-34T
Chain	KMC X9
Wheelset	Shining (AS19) / Formula HUB (RX-25/26)
Tyres	Kenda Flintridge 700X35c
Saddle	Cinelli SSM Era
Tape	Cinelli VLG 1192

frame specs

Sizes	XS (48) - S (52) - M (55) - L (58) - XL (60)
Material	Columbus Cromor Double Butted Steel
Headset	EC 34/28,6 EC 34/30
Seatpost	Ø 27,2 mm
Seat Clamp	Clamp Ø29,8 mm
BB Shell	BSA 68 mm
Ft. derailleur	Clamp on Ø28,6 mm
Routing	External
Color	Blue Sea
Tyre Clear.	Up to 700x40 With Fenders - Up to 700x44 Without Fenders
Fork	Columbus Cr-Mo Steel 1" - 1/8
Weight	Frame 2150 g. (size M) Fork 1050 g. (uncut)
Brake	Disc, Post Mount
Dropouts ST	Front QR 100mm - Rear QR 135mm
Highlights	Front Rack Middle Fork - Rear Rack Eyelet / Fender Eyelet

supercorsa pista

The world's most famous classic Italian track bike, in uninterrupted production since the early 1950s



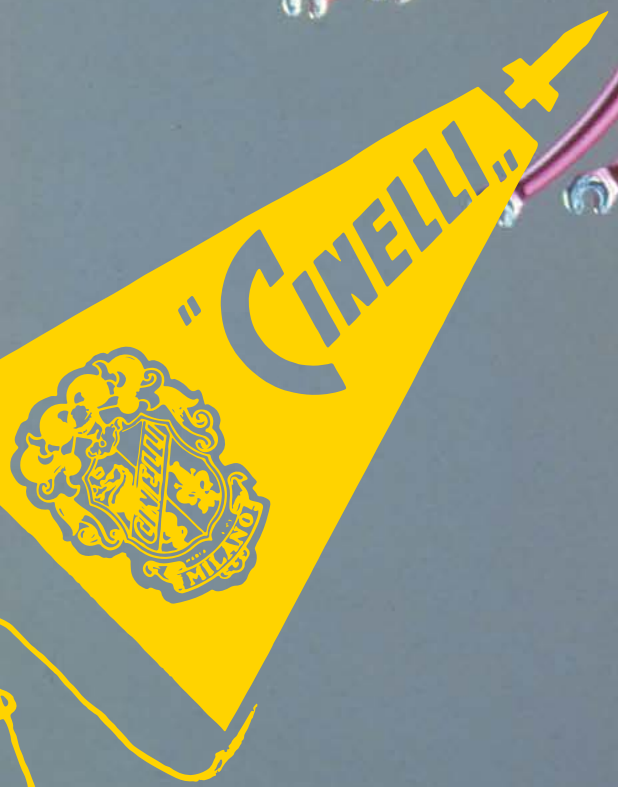
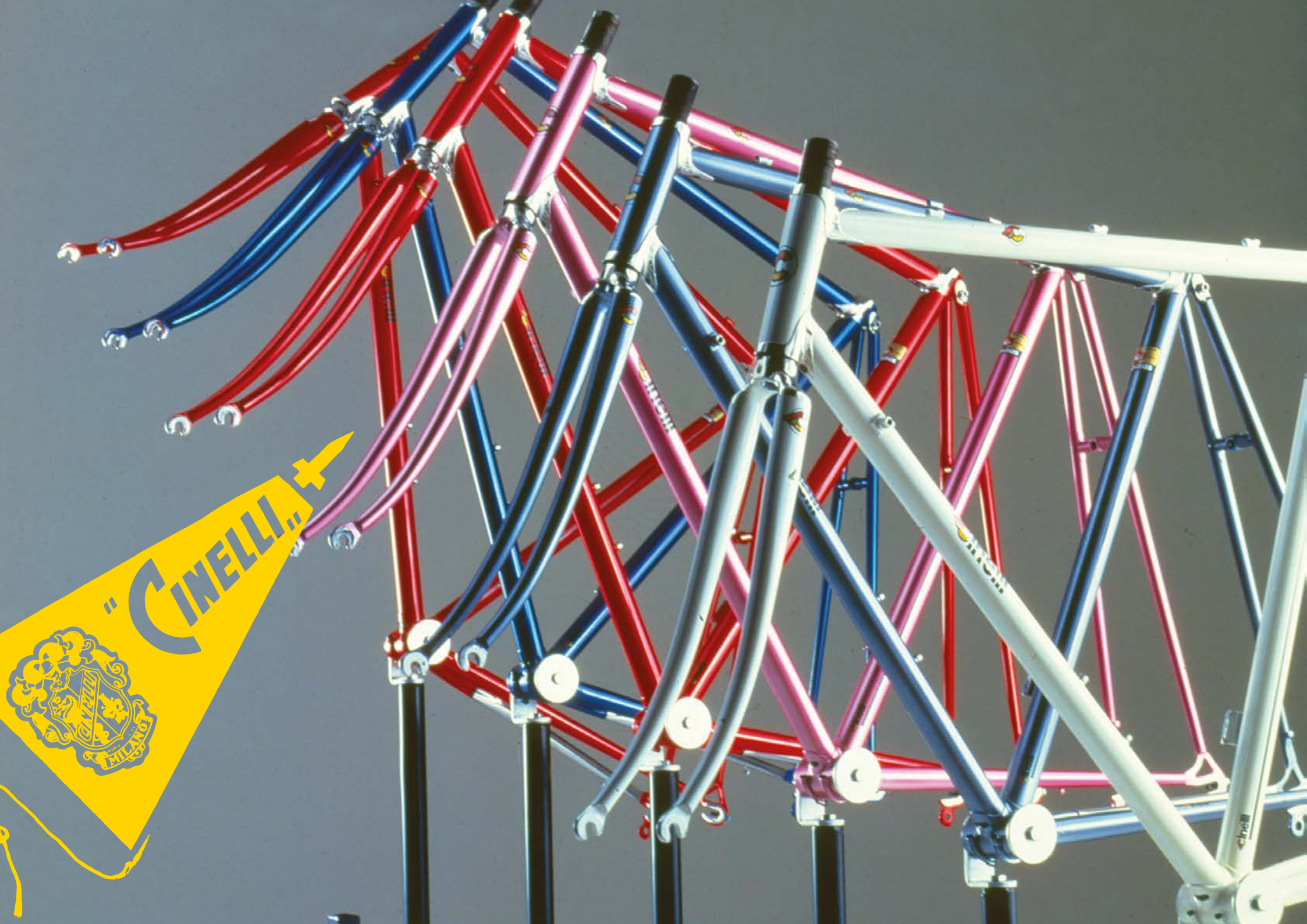

supercorsa pista

frame-kit

- The ultimate classic Italian track bike, In uninterrupted production since the early 1950s
- 100% Made in Italy from Italian materials
- Still manufactured according the original specifications perfected by Cino Cinelli during the 1950s
- Original Cino Cinelli velodrome track geometry
- Available in 13 sizes and 8 colours

The Supercorsa is the world's most famous classic Italian track bike, still today 100% Made in Italy from Italian materials respecting the same geometries and specifications of Cino Cinelli. Afficionados of classic Italian bikes will appreciate not just the unsurpassed ride quality of the frame but also the meticulous craftsmanship and luxurious detailing.



specs

FRAME WEIGHT (M)	FORK WEIGHT (M)	BOTTOM BRACKET	MAX TYRE
1780 g	670 g	ITA	25 mm

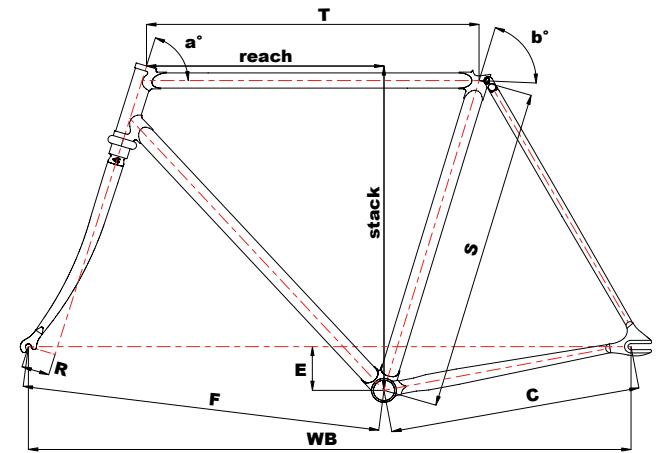

frame specs

Sizes	49 to 61 (1 cm) - Made to Measure
Material	Columbus Sirtt Super Pista Double Butted Tubeset
Headset	EC 30/25,4-24TPI EC 30/26
Seatpost	Ø 27,2 mm
Seat Clamp	Integrated
BB Shell	ITA 70 mm
Ft. derailleur	/
Routing	/
Color	Rosso Ferrari-Bianco Perla-Azzurro Laser-Titanium Grey-Verde Jaguar-Black Tie-Blu China-Giallo Curry
Tyre Clear.	up to 700x25 mm
Fork	Columbus SL Pista 1" Threaded
Weight	Frame 1780 g. (size M) Fork 670 g. (uncut)
Brake	/
Dropouts ST	Front QR 100 mm - Rear QR 120 mm
Highlights	Frame / Fork

Colori di serie:



geometry

	T	A	B	R	C	F	WB	E	STACK	REACH
49	510	72	75	35	388	567	946	60	488	379
50	520	73	75	35	388	566	946	60	500	385
51	525	73	75	35	388	568	948	60	505	389
52	535	73	75	35	388	569	949	60	515	397
53	540	73	75	35	388	571	951	60	520	401
54	545	74	75	35	388	572	952	60	532	402
55	550	74	75	35	388	575	955	60	542	405
56	555	74,5	74,5	35	388	578	958	60	553	402
57	560	74,5	74	35	390	580	962	60	562	399
58	565	74,5	74	35	390	585	967	60	567	402
59	570	75	74	35	390	583	965	60	578	404
60	575	75	74	35	390	586	968	60	588	407
61	580	75	74	35	390	592	975	60	598	409



GRUPPO SRL - CINELLI DIVISION
VIA G. DI VITTORIO 21 - 20049 CALEPPIO DI SETTALA (MI) - ITALY
TEL +39-02-95244.1 FAX +39-02-95244.239
www.cinelli-milano.com - info@cinelli-milano.com

The information published in this catalogue are indicative, not binding. Gruppo S.r.l. - Cinelli Division reserves the right to make changes and improvements without prior notice.

aido

